

■ Details

The EF Series

NOTE: FASTEN FURRING INTO
ALIGNED STUD OR HORIZONTAL
BLOCKING. SPACING PER ENGINEER-
ING, 2'-0" O.C. MAX

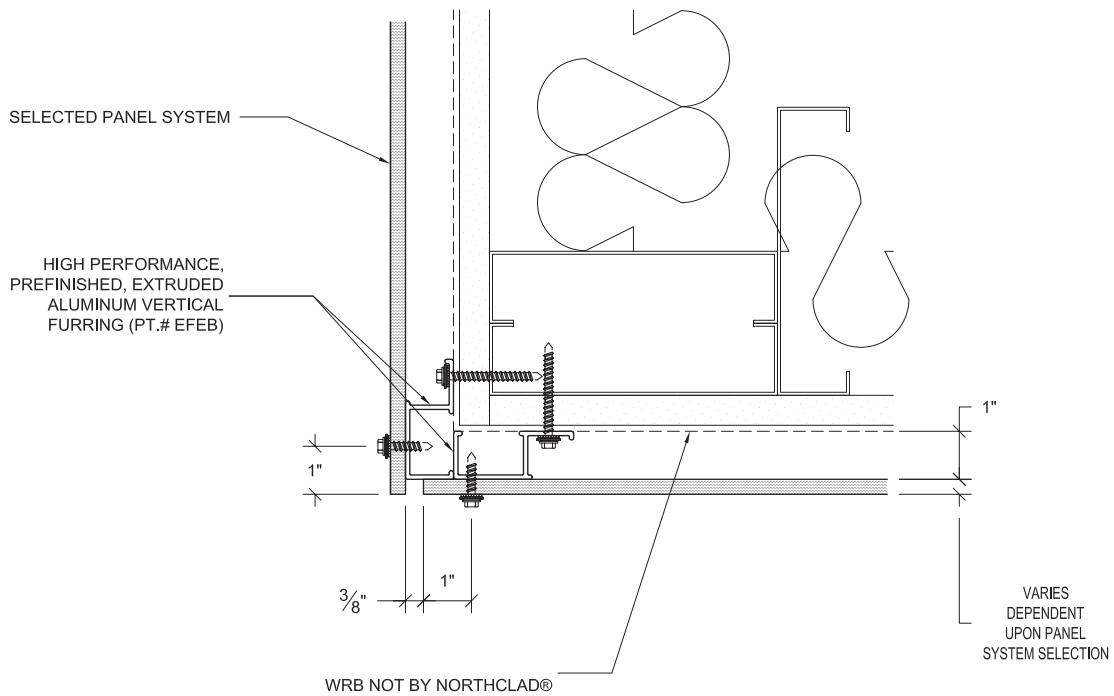

For details without exterior insulation, or to download the CAD version of this detail, please see www.northclad.com.

© 2009 NorthClad® Rainscreen Solutions
Everett, WA · (425) 487-1111



Outside Corner

Scale: 3" = 1' - 0"