

Details	2
ACM Detail Reference	2
Base Detail	5
Coping	6
Coping Joint	7
Door Head	13
Door Jamb Left	16
Door Jamb Right	19
Horizontal Joint	3
Inside Corner	10
Louver Head	12
Louver Jamb Left	15
Louver Jamb Right	18
Louver Sill	21
Outside Corner	9
Sheet Metal Coping	8
Vertical Joint	4
Window Head	11
Window Jamb Left	14
Window Jamb Right	17
Window Sill	20

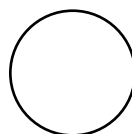

ACM Detail Reference

Scale: NTS

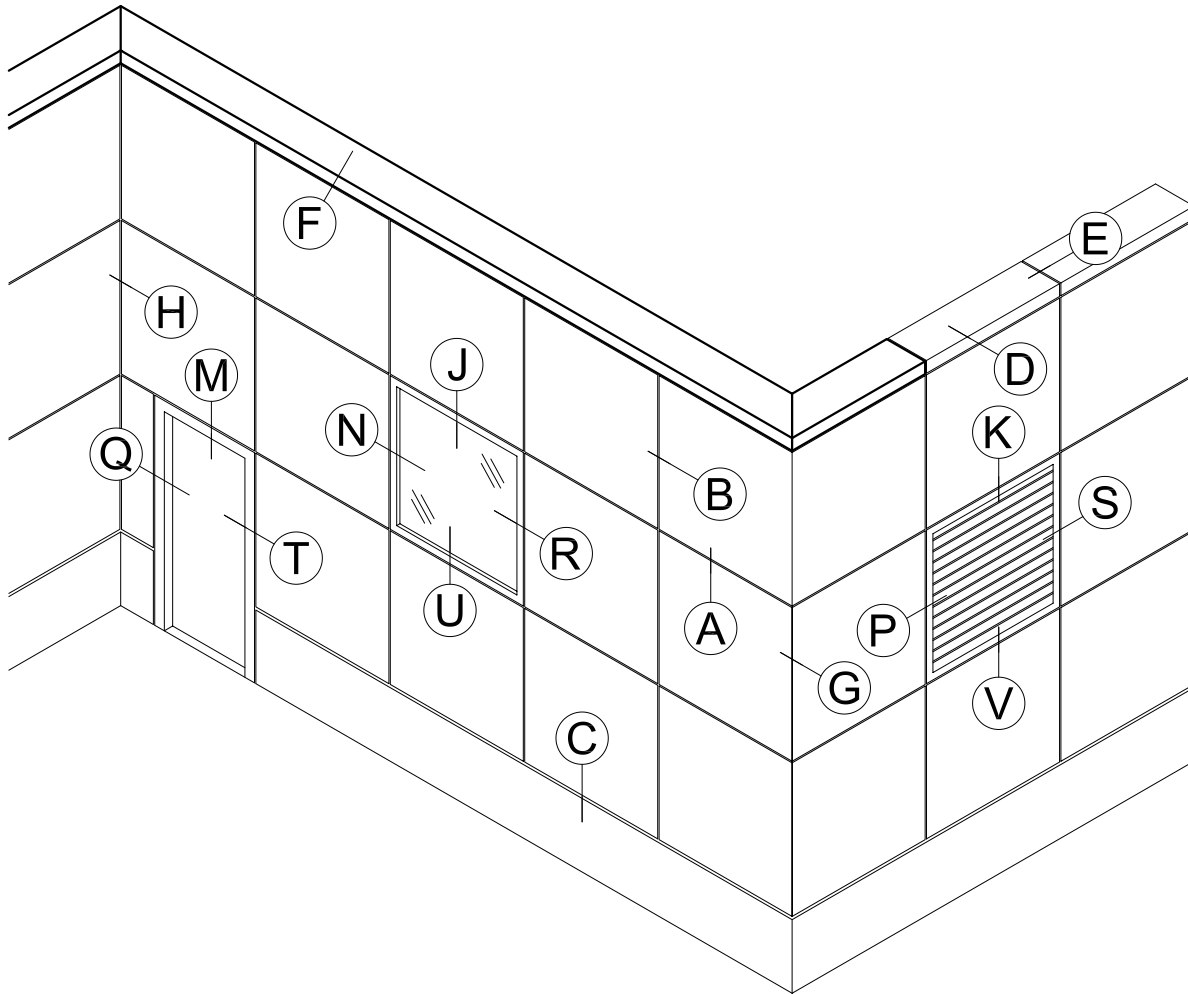
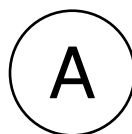
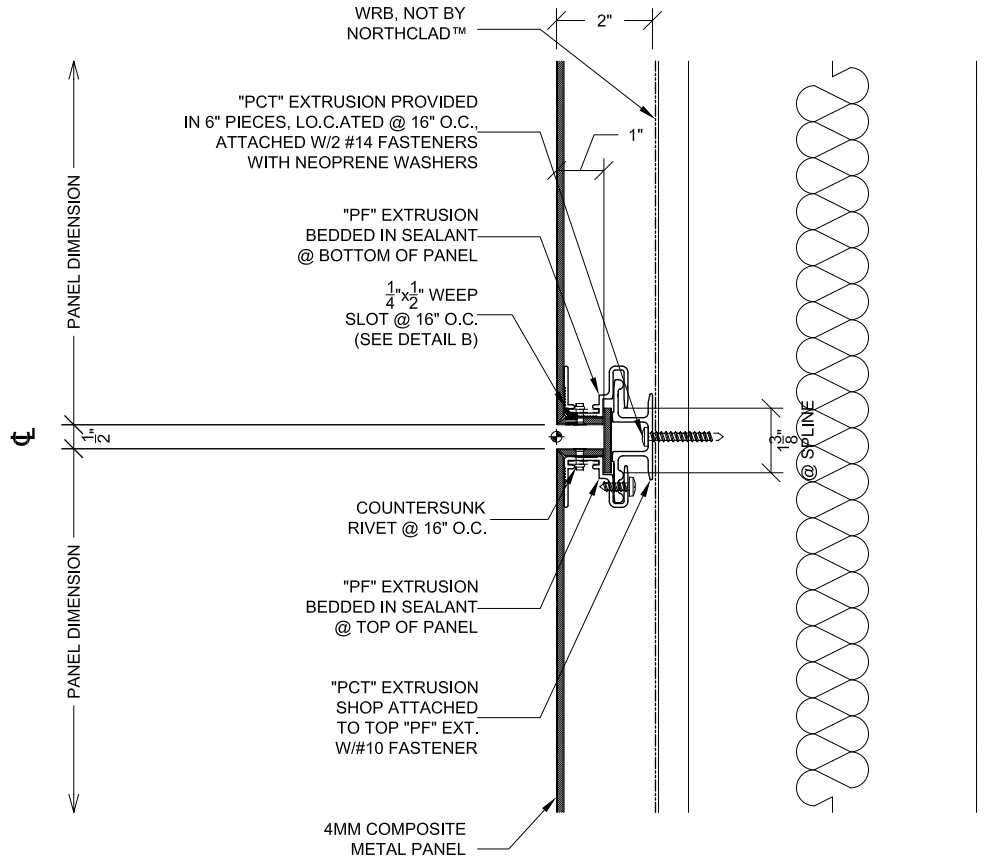

Horizontal Joint

Scale: 3" = 1' - 0"

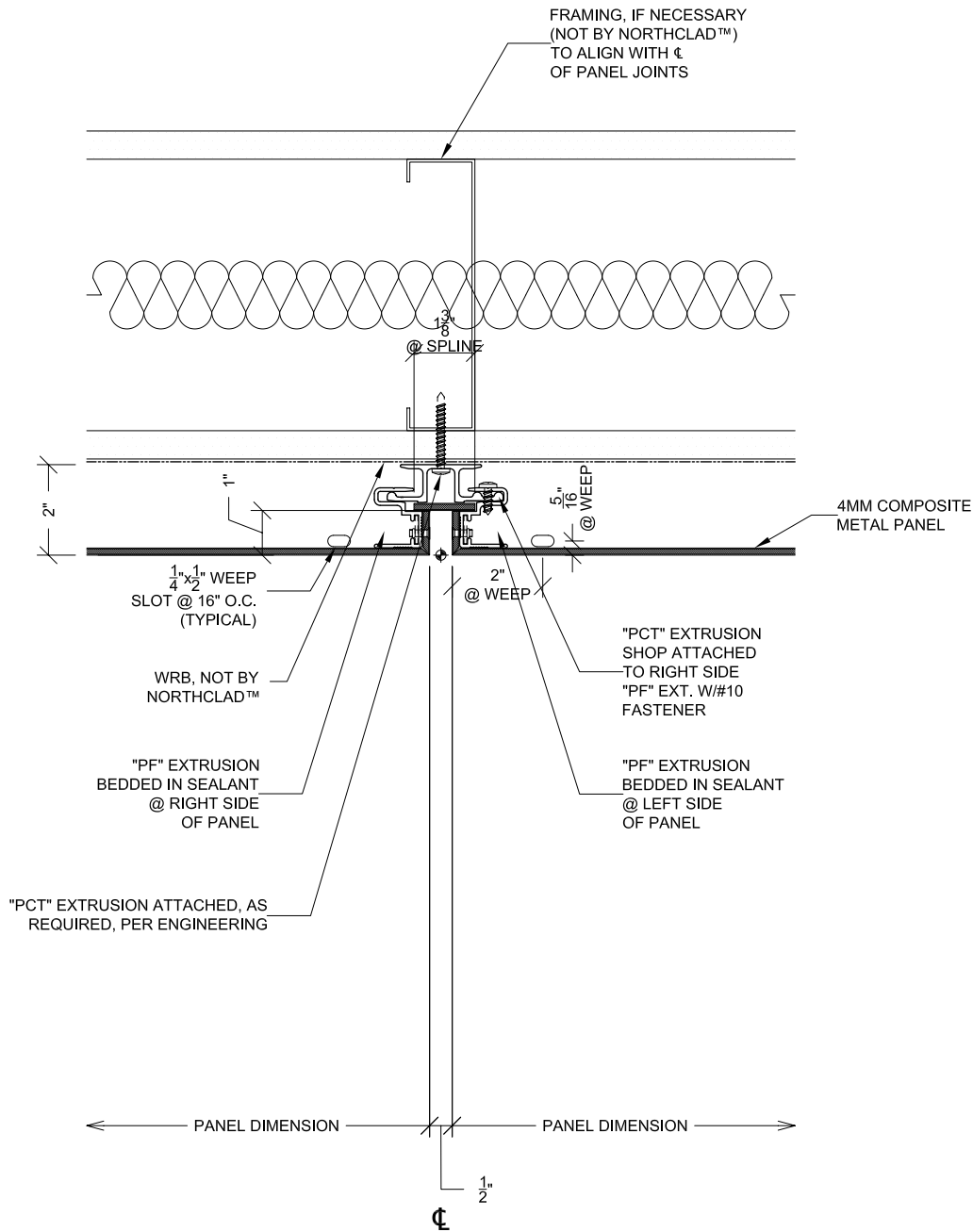

B

Vertical Joint

Scale: 3" = 1' - 0"

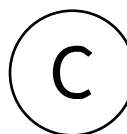
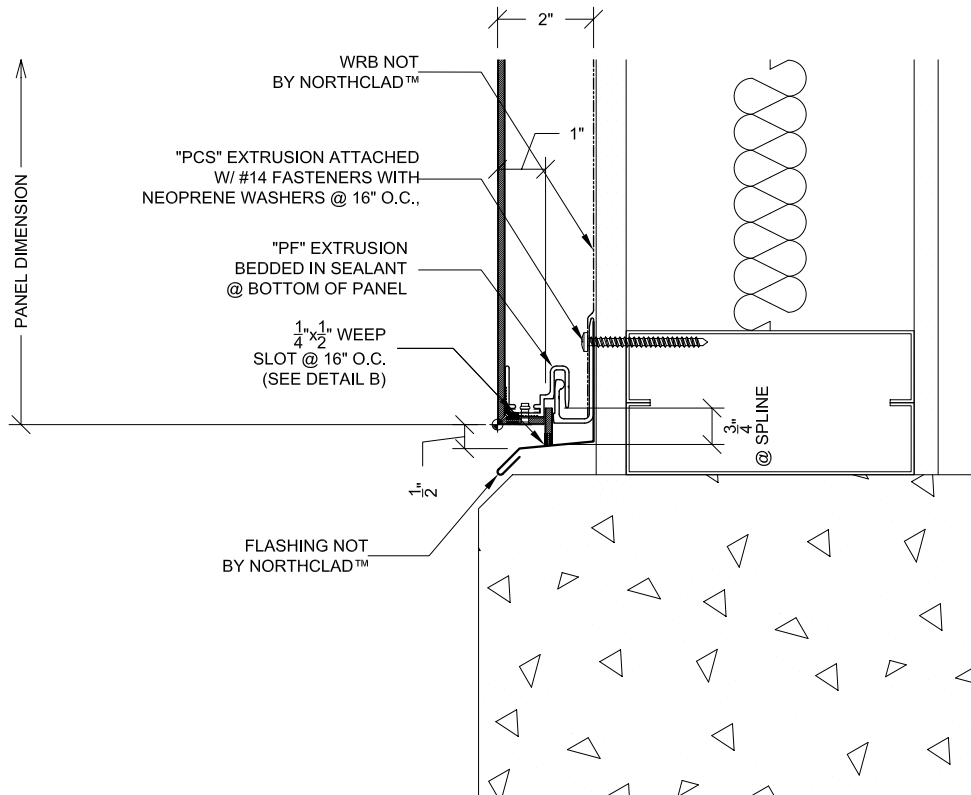

Base Detail

Scale: 3" = 1' - 0"

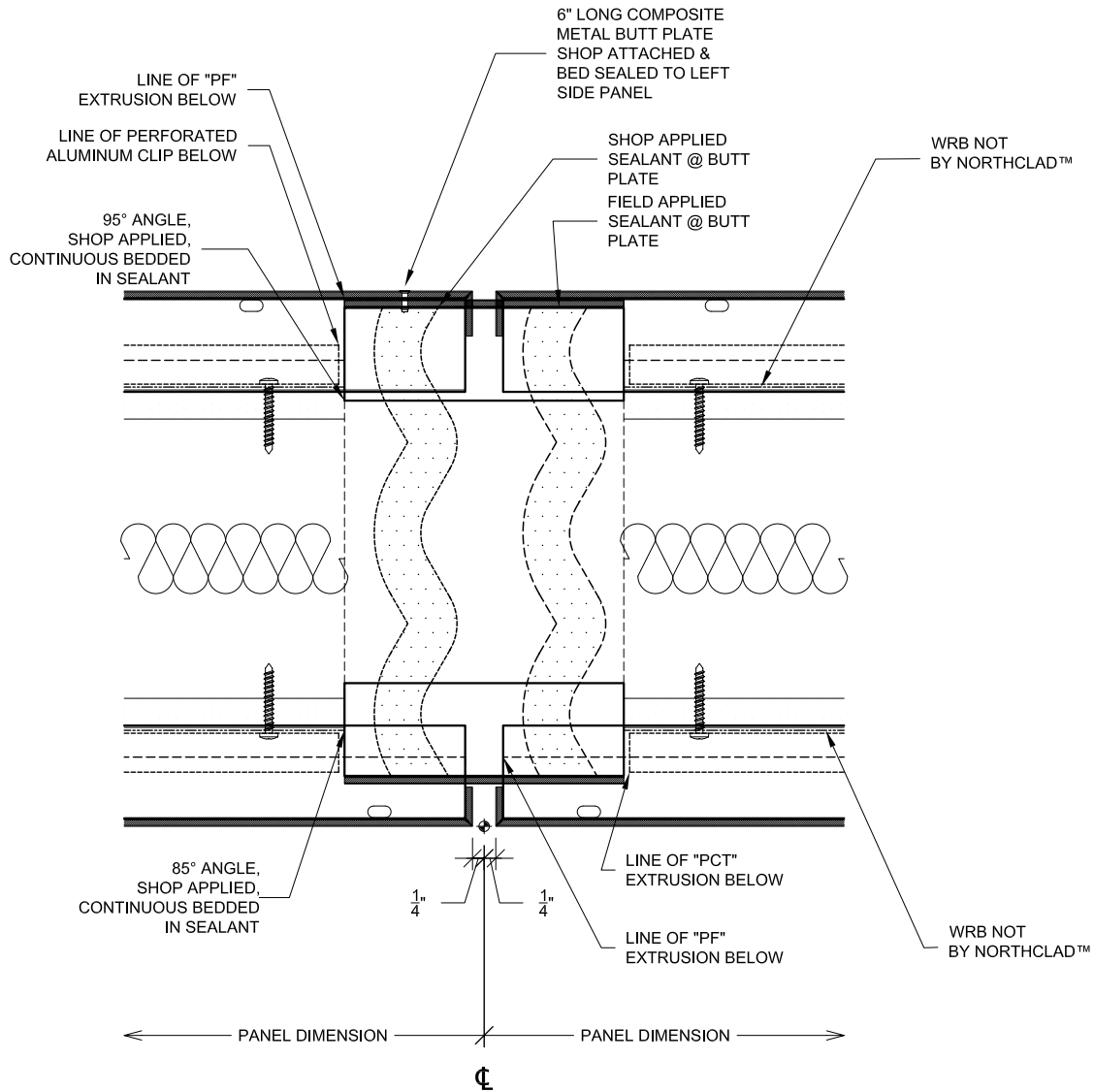

E

Coping Joint

Scale: 3" = 1' - 0"

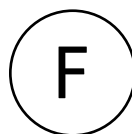
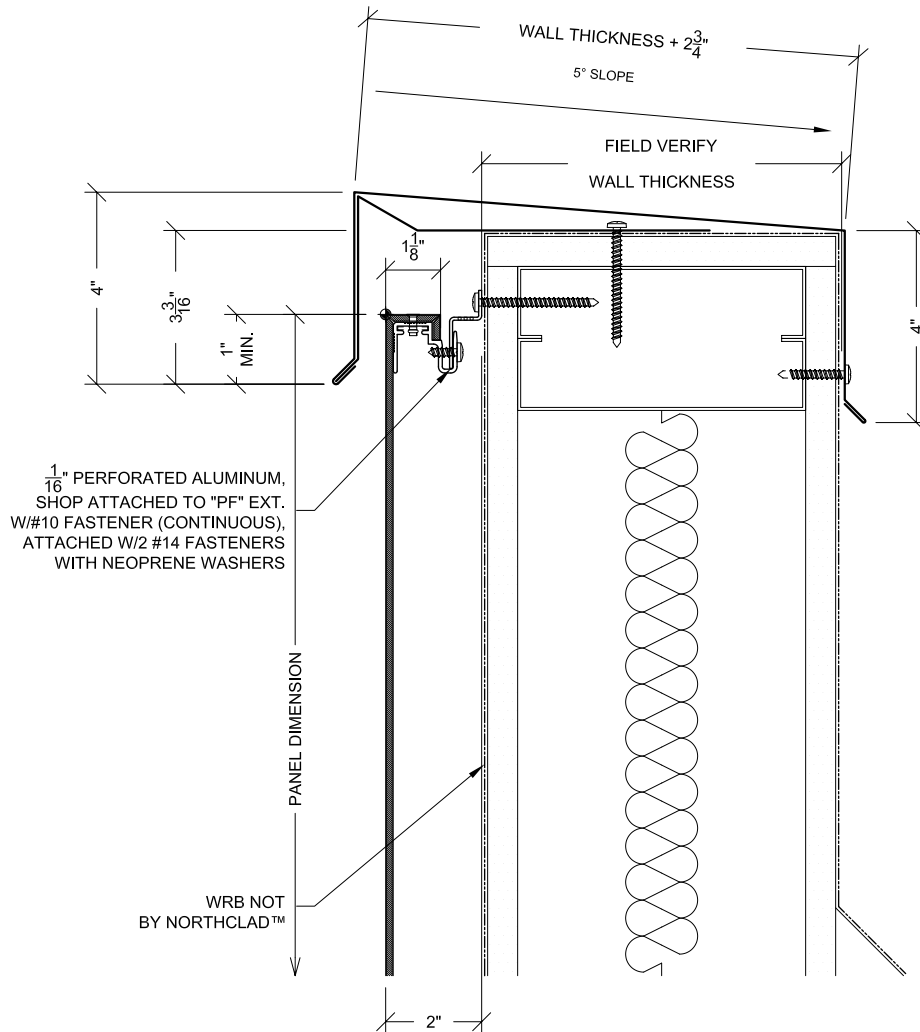

Sheet Metal Coping

Scale: 3" = 1' - 0"

The ACM Series

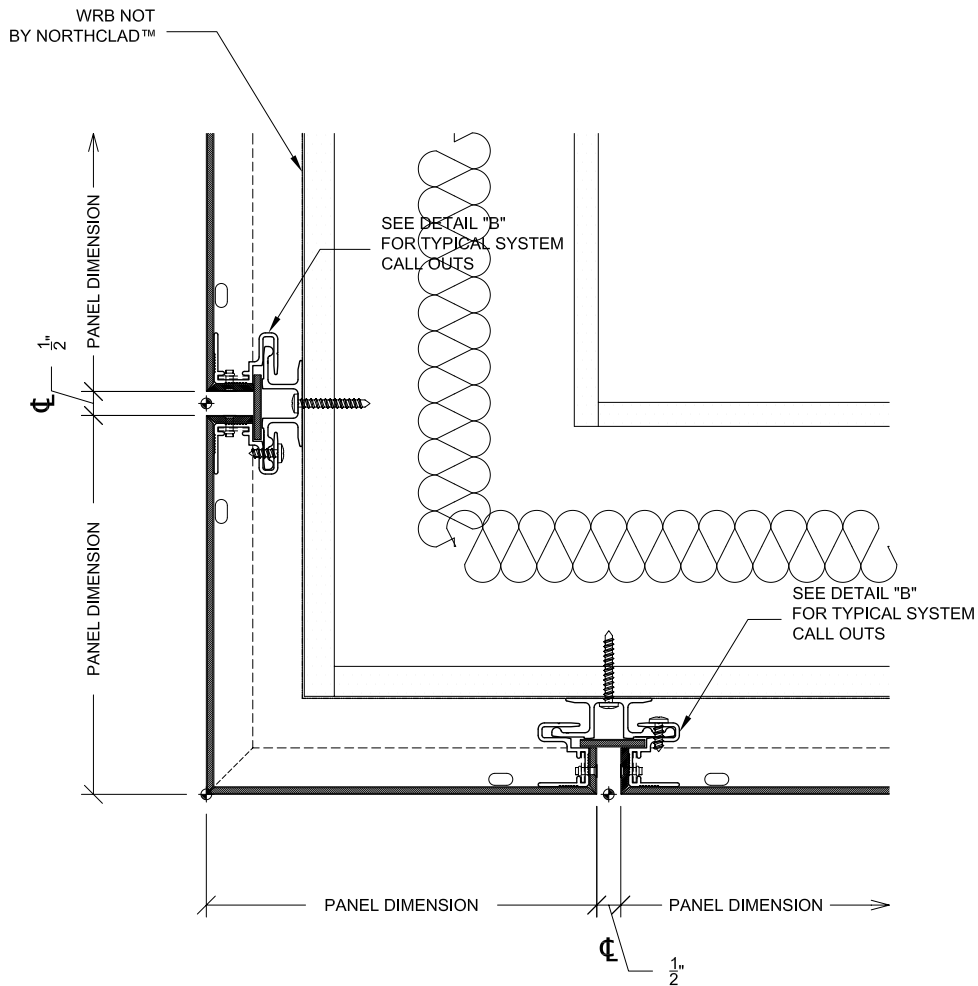

Outside Corner

Scale: 3" = 1' - 0"

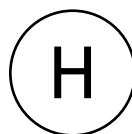
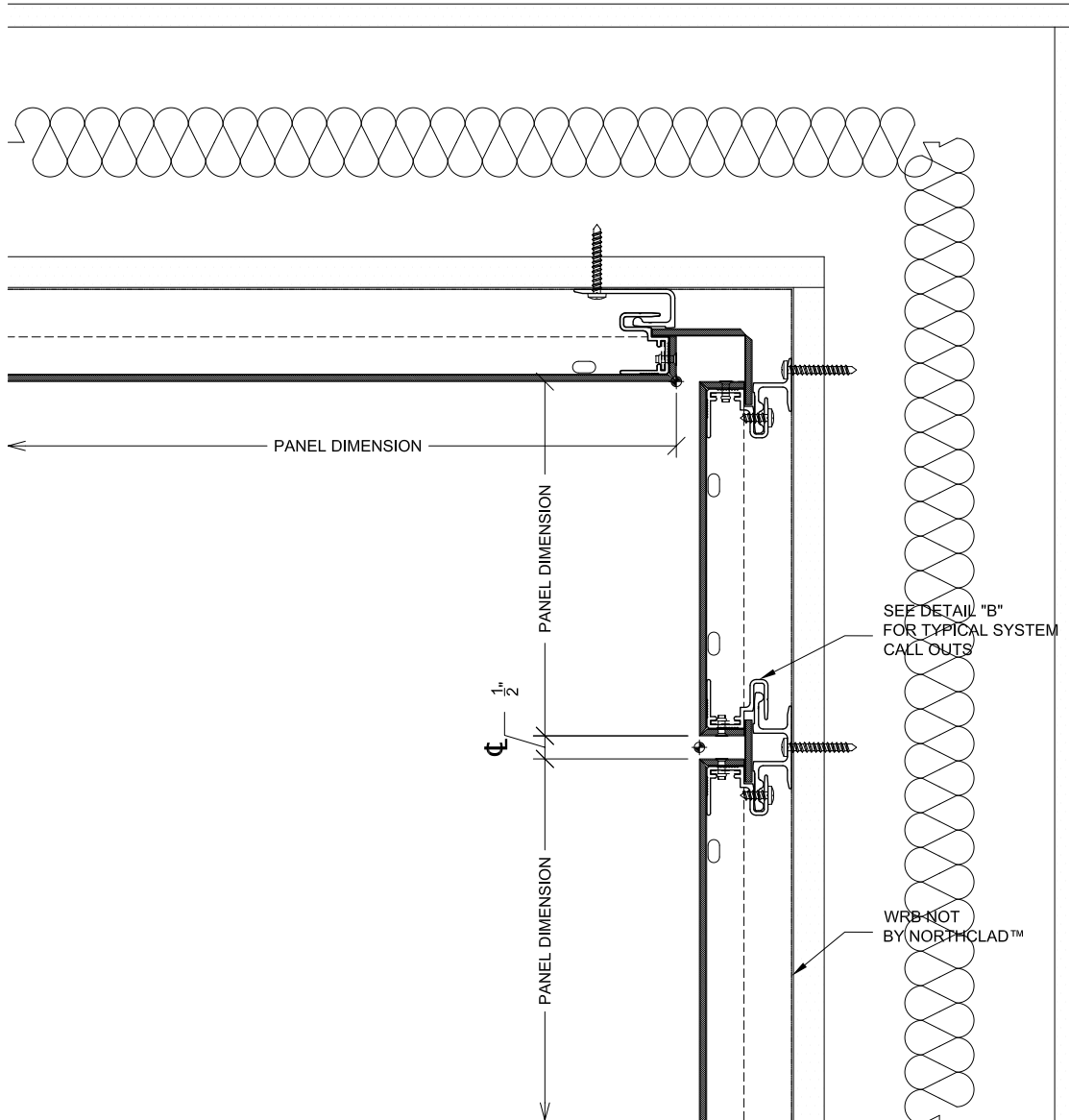

Inside Corner

Scale: 3" = 1' - 0"

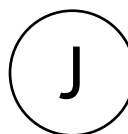
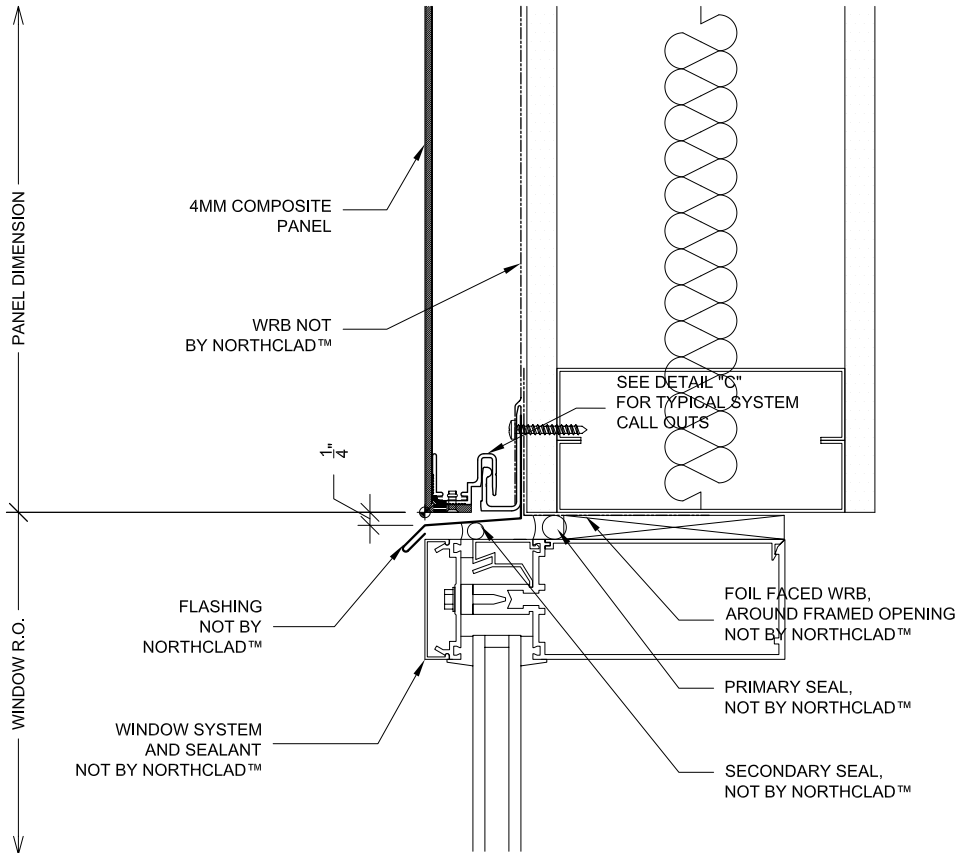

Window Head

Scale: 3" = 1' - 0"

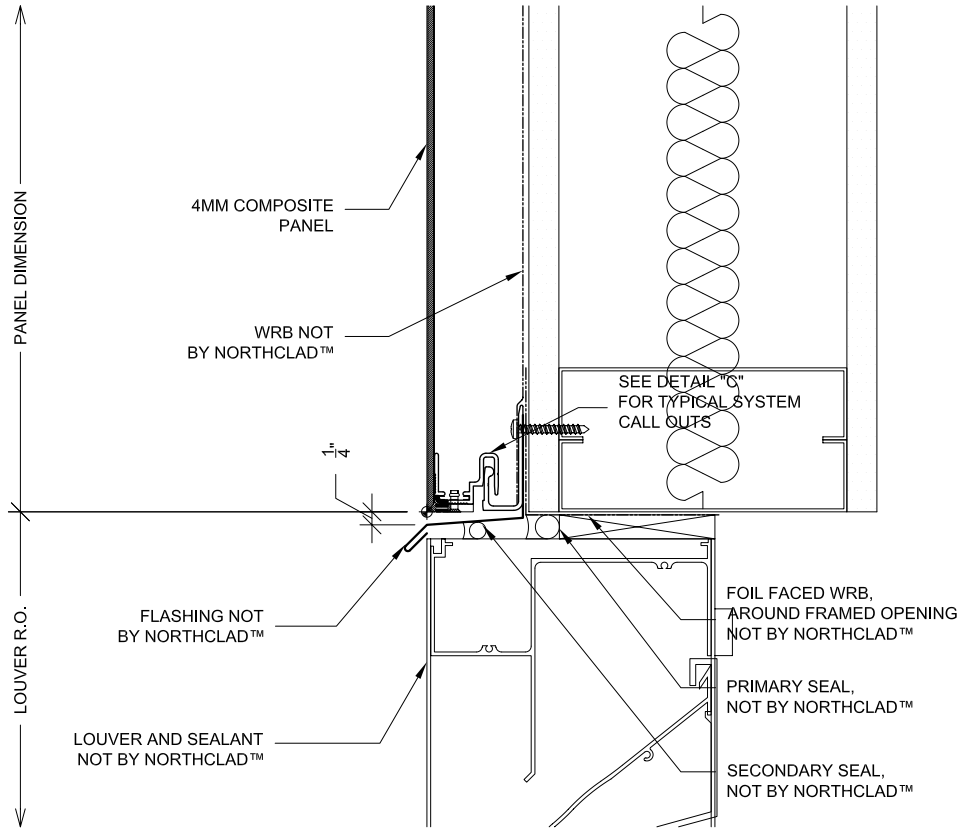

K

Louver Head

Scale: 3" = 1' - 0"

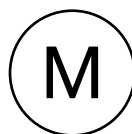
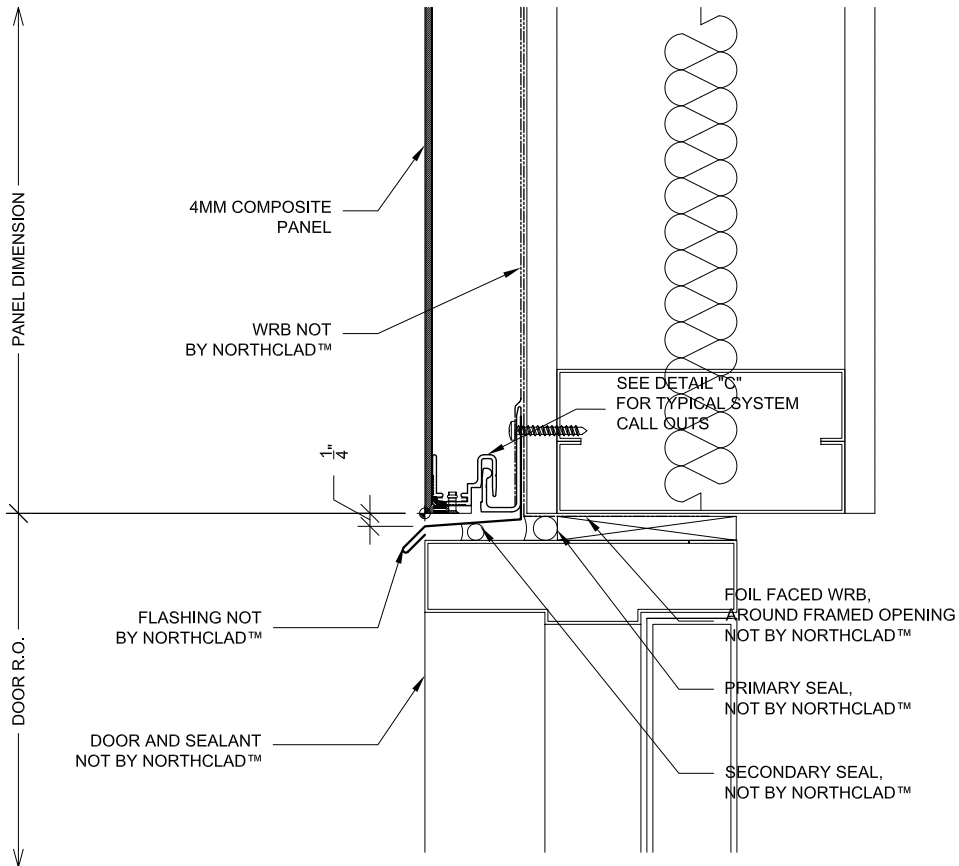

Door Head

Scale: 3" = 1' - 0"

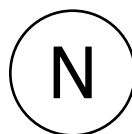
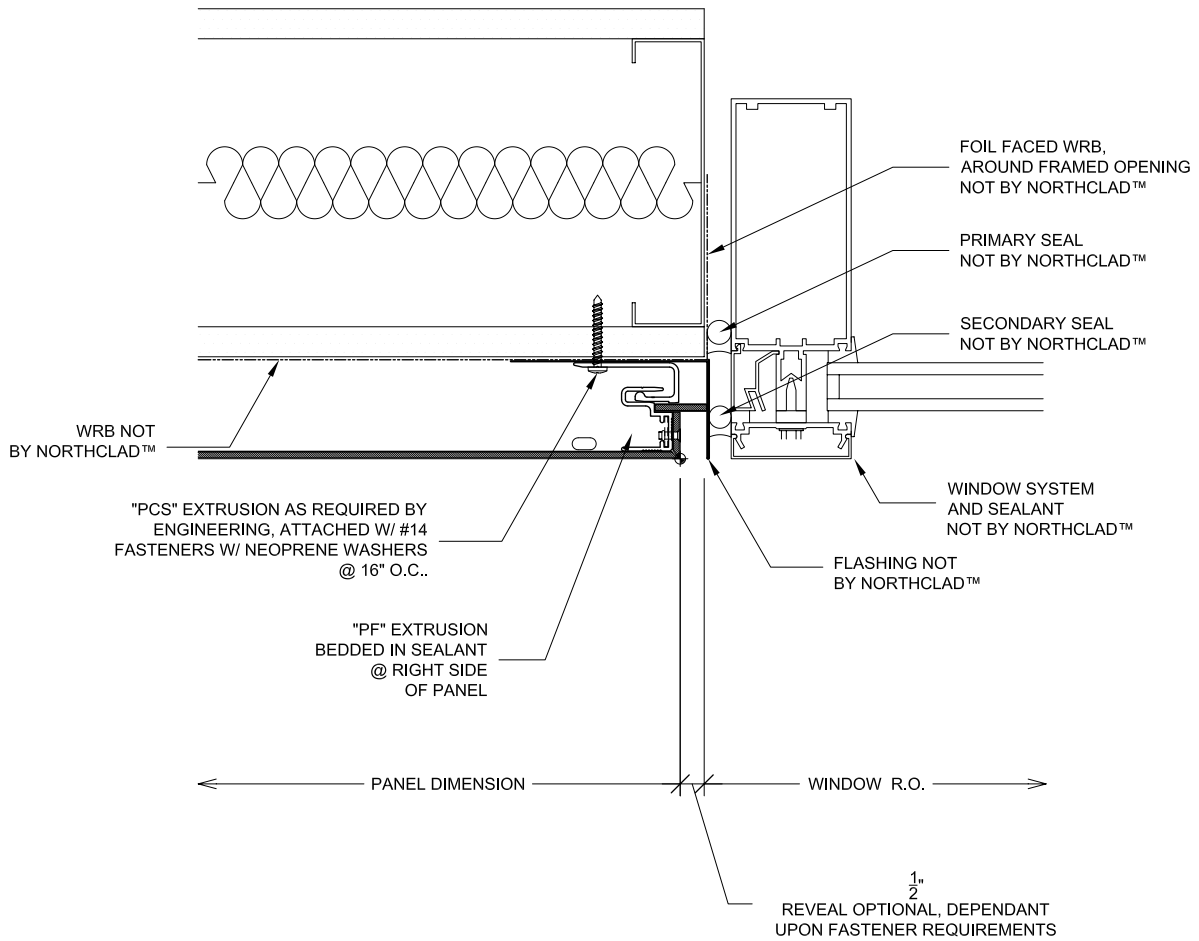

Window Jamb Left

Scale: 3" = 1' - 0"

The ACM Series

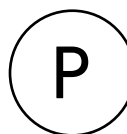
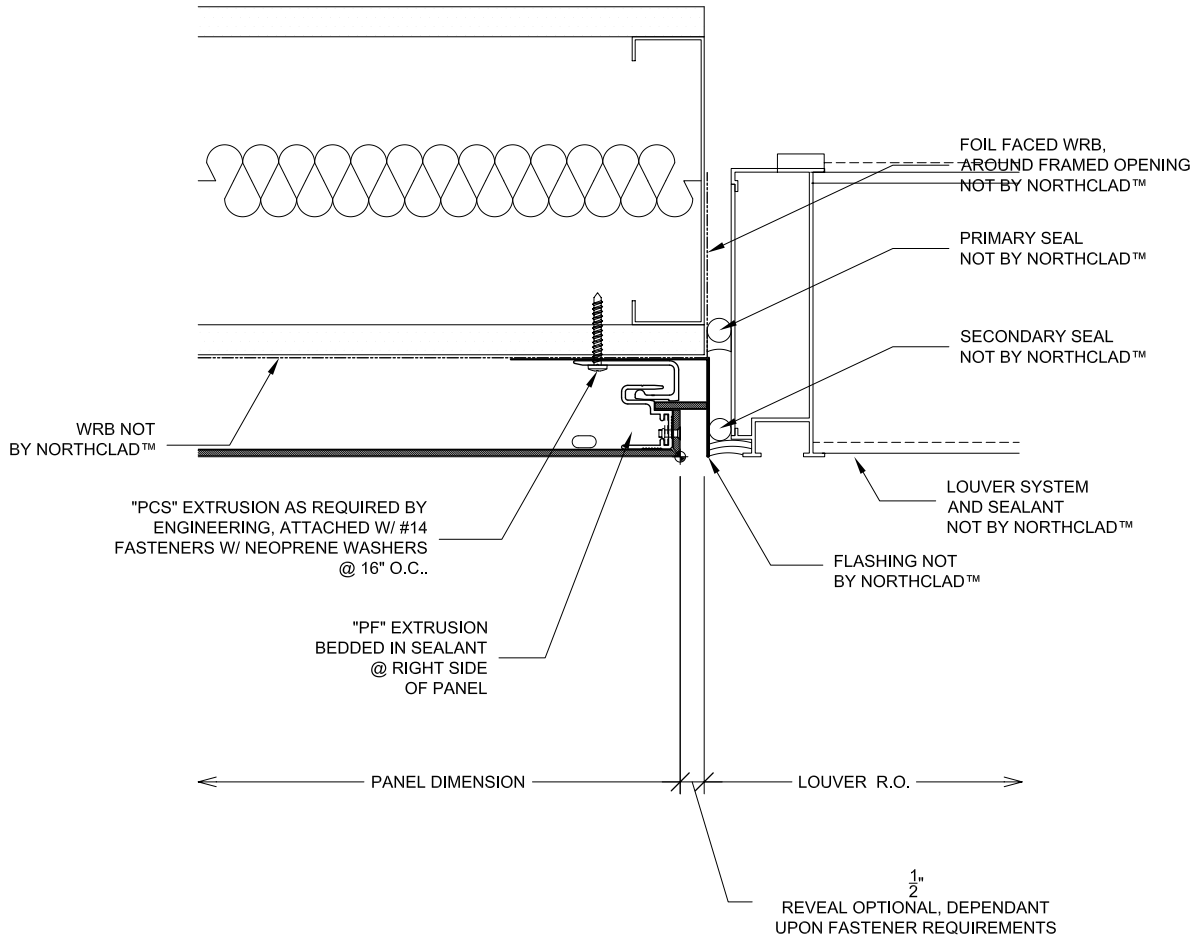

Louver Jamb Left

Scale: 3" = 1' - 0"

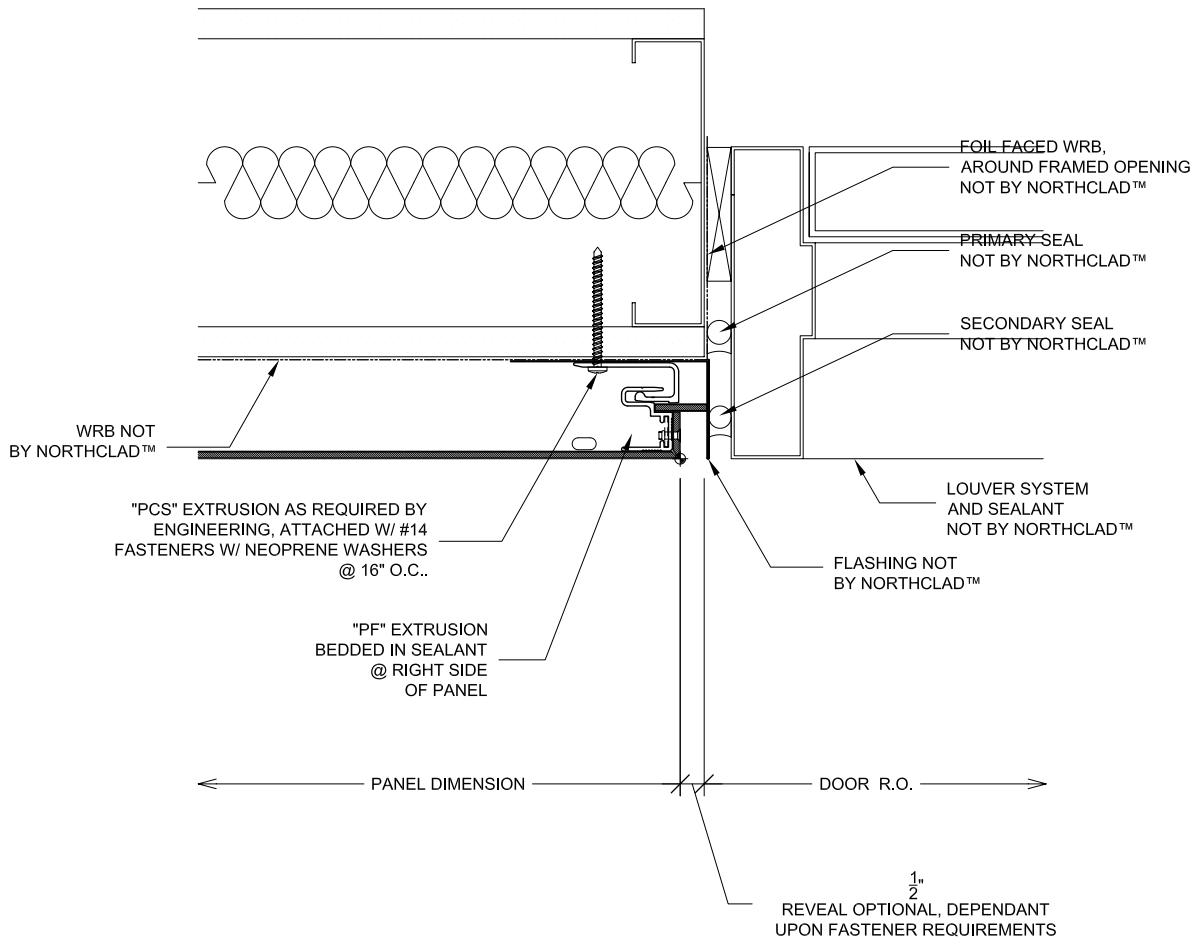

Door Jamb Left

Scale: 3" = 1' - 0"

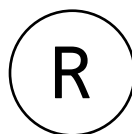
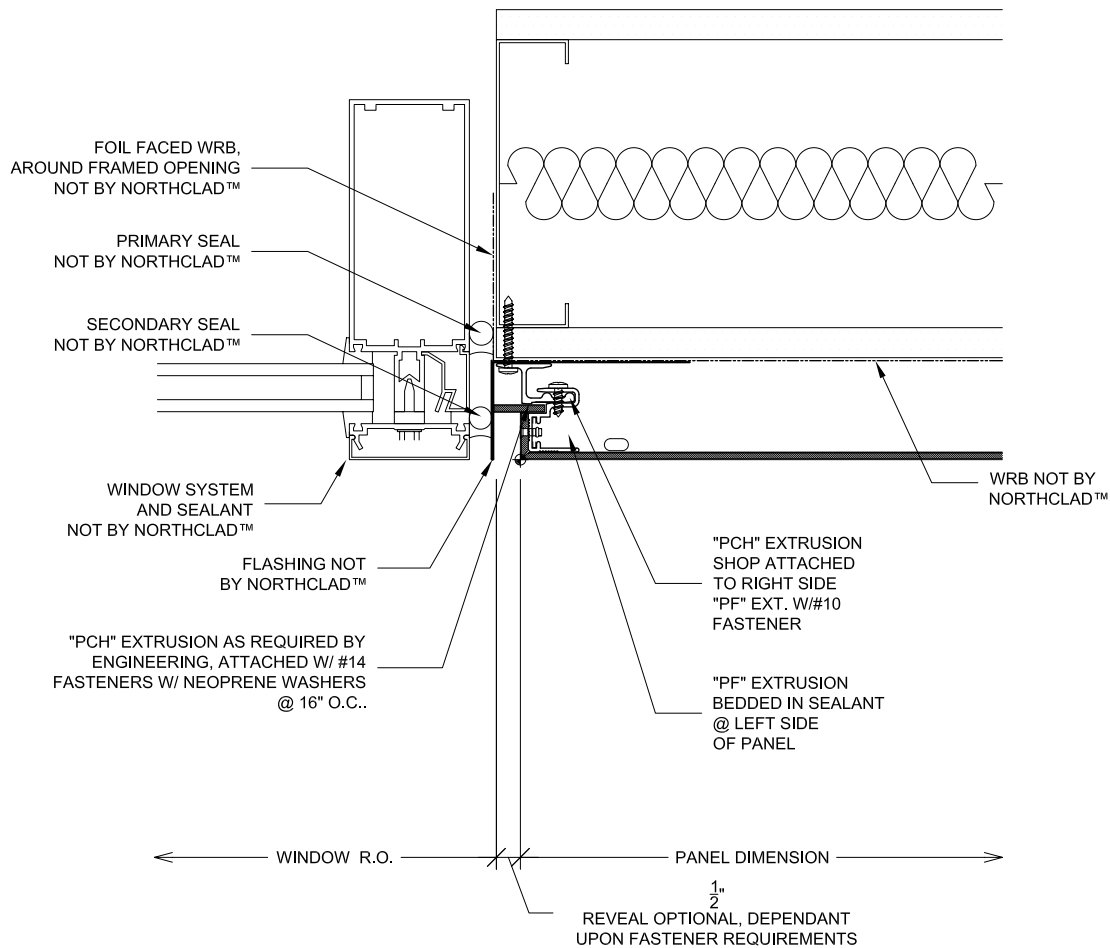

Window Jamb Right

Scale: 3" = 1' - 0"

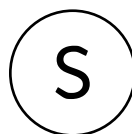
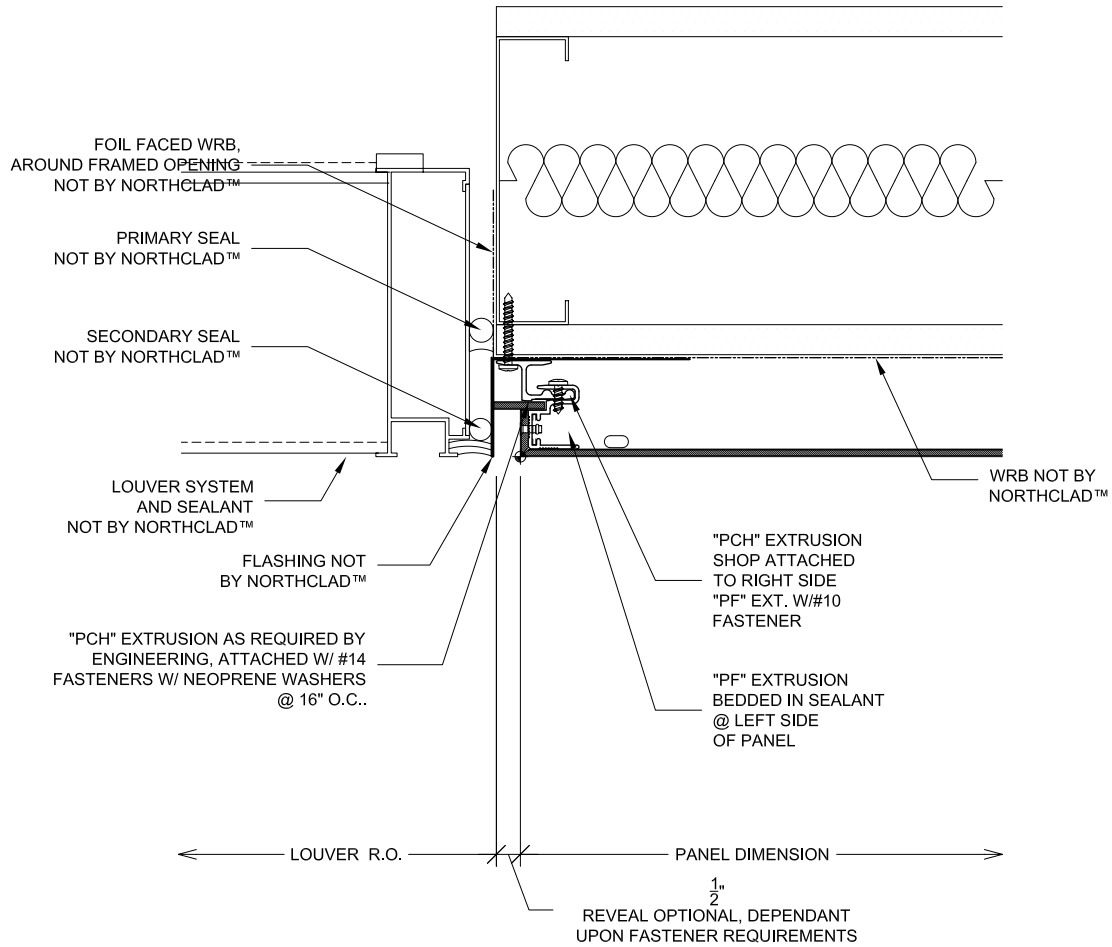

Louver Jamb Right

Scale: 3" = 1' - 0"

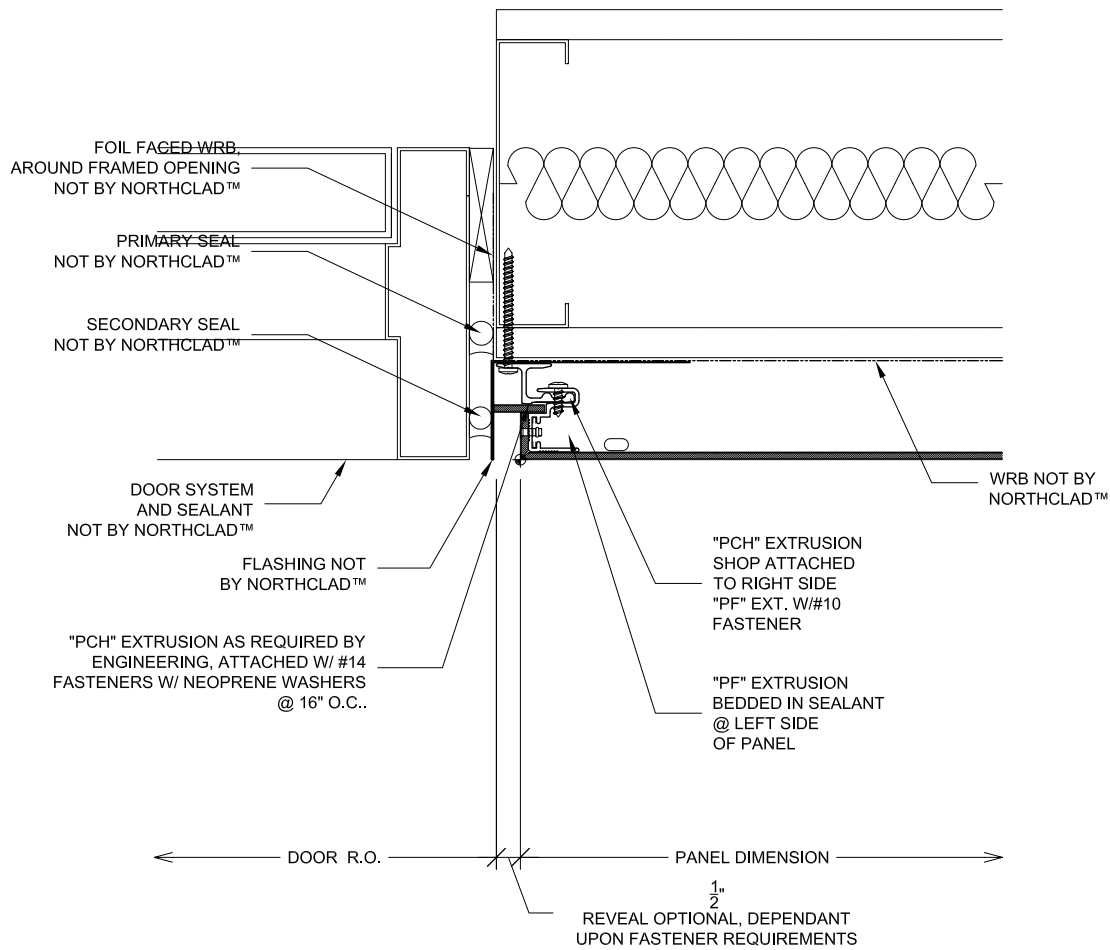

Door Jamb Right

Scale: 3" = 1' - 0"

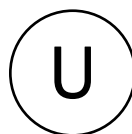
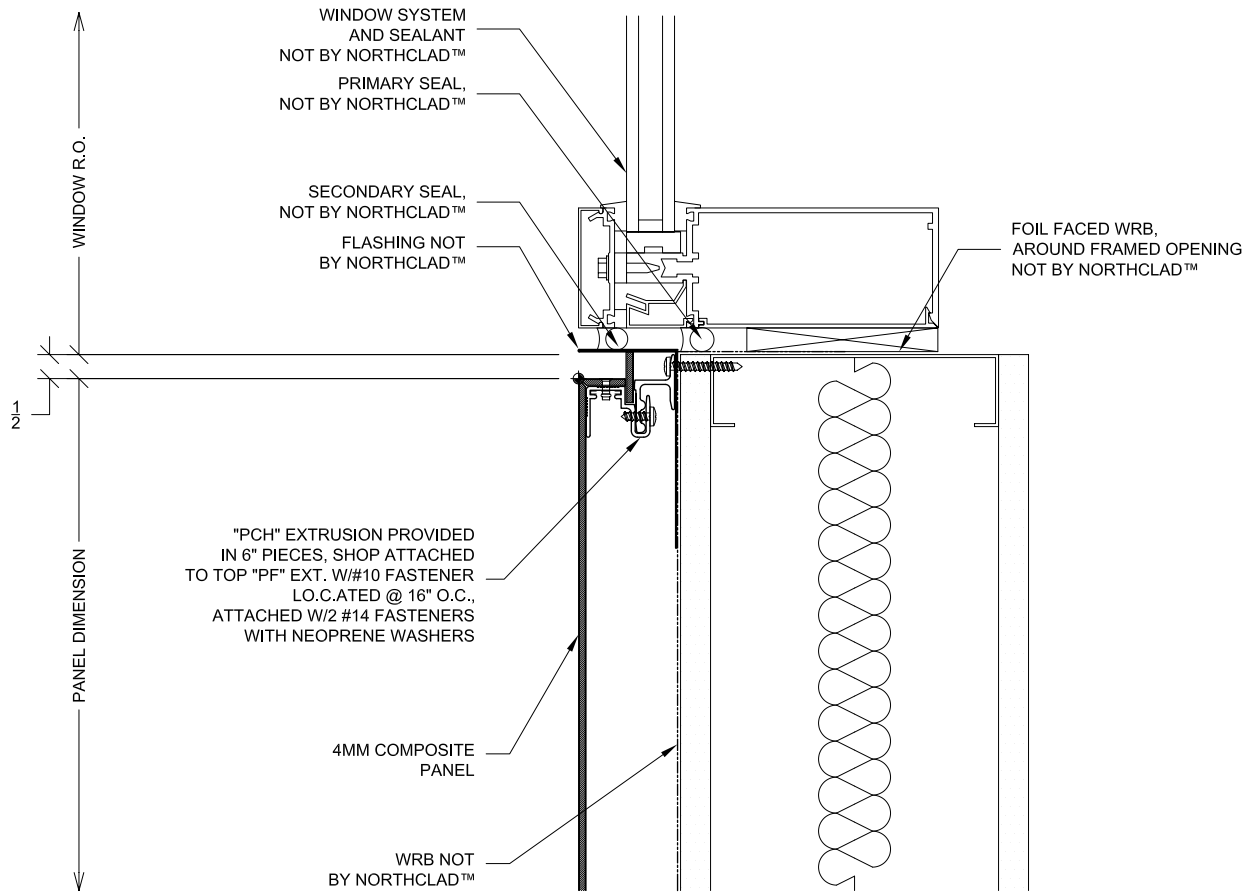

Window Sill

Scale: 3" = 1' - 0"

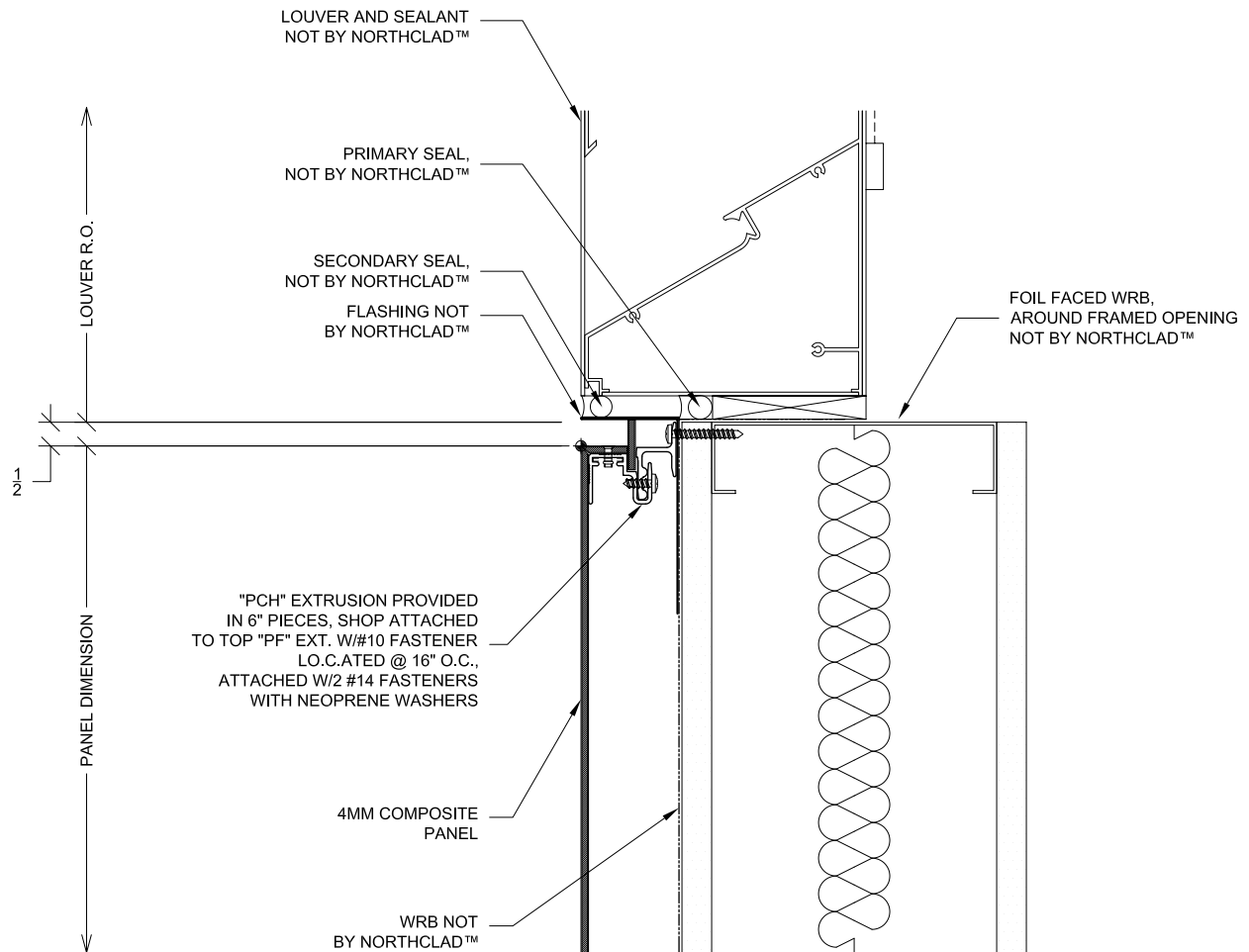

Louver Sill

Scale: 3" = 1' - 0"