

11831 BEVERLY PARK RD. BUILDING C, EVERETT, WA 98204
 * PHONE: 425.740.3702 * FAX: 425.740.3701 *
 www.northclad.com

This document is property of NorthClad and should not be used, duplicated or modified without the express written consent. Copyright © 2010 NorthClad All Rights Reserved

NO.	DESCRIPTION	DATE	INIT.
1	Std Details	02.12.2014	M E
2			
3			
4			
5			
6			
7			
8			
9			
10			

Project

ALP Dry Joint

Sheet Title
DET

Scale

Job Number

Sheet
Key Elev

APPROVED

INDEX 1

- A. Section - Typical ALP Horizontal Panel Joint
- B. Plan - Typical ALP Vertical Panel Joint
- C. Section - ALP Base of Panel Wall
- D. Section - ALP Panel Coping
- E. Plan - ALP Panel Coping Splice
- F. Section - ALP Panel at Light Gauge Formed Coping
- G. Plan - ALP Outside Corner
- H. Plan - ALP Inside Corner
- J. Section - ALP Panel at Window/CW Head
- K. Section - ALP Panel at Louver Head
- M. Section - ALP Panel at Hollow Metal Door Head
- N. Plan - ALP Panel at Left Side Window/CW Jamb
- P. Plan - ALP Panel at Left Side Louver Jamb
- Q. Plan - ALP Panel at Left Side Hollow Metal Door Jamb
- R. Plan - ALP Panel at Right Side Window/CW Jamb
- S. Plan - ALP Panel at Right Side Louver Jamb
- T. Plan - ALP Panel at Right Side Hollow Metal Door Jamb
- U. Section - ALP Panel at Window/CW Sill
- V. Section - ALP Panel at Louver Sill



11831 BEVERLY PARK RD. BUILDING C, EVERETT, WA 98204
 * PHONE: 425.740.3702 * FAX: 425.740.3701 *
www.northclad.com

This document is property of NorthClad and should not be used, duplicated or modified without the express written consent. Copyright © 2010 NorthClad All Rights Reserved

NO.	DESCRIPTION	DATE	INIT.
1	Std Details	02.12.2014	M E
2			
3			
4			
5			
6			
7			
8			
9			
10			

Project

ALP Dry Joint

Sheet Title **DET**

Scale

Job Number

Sheet

Index

APPROVED

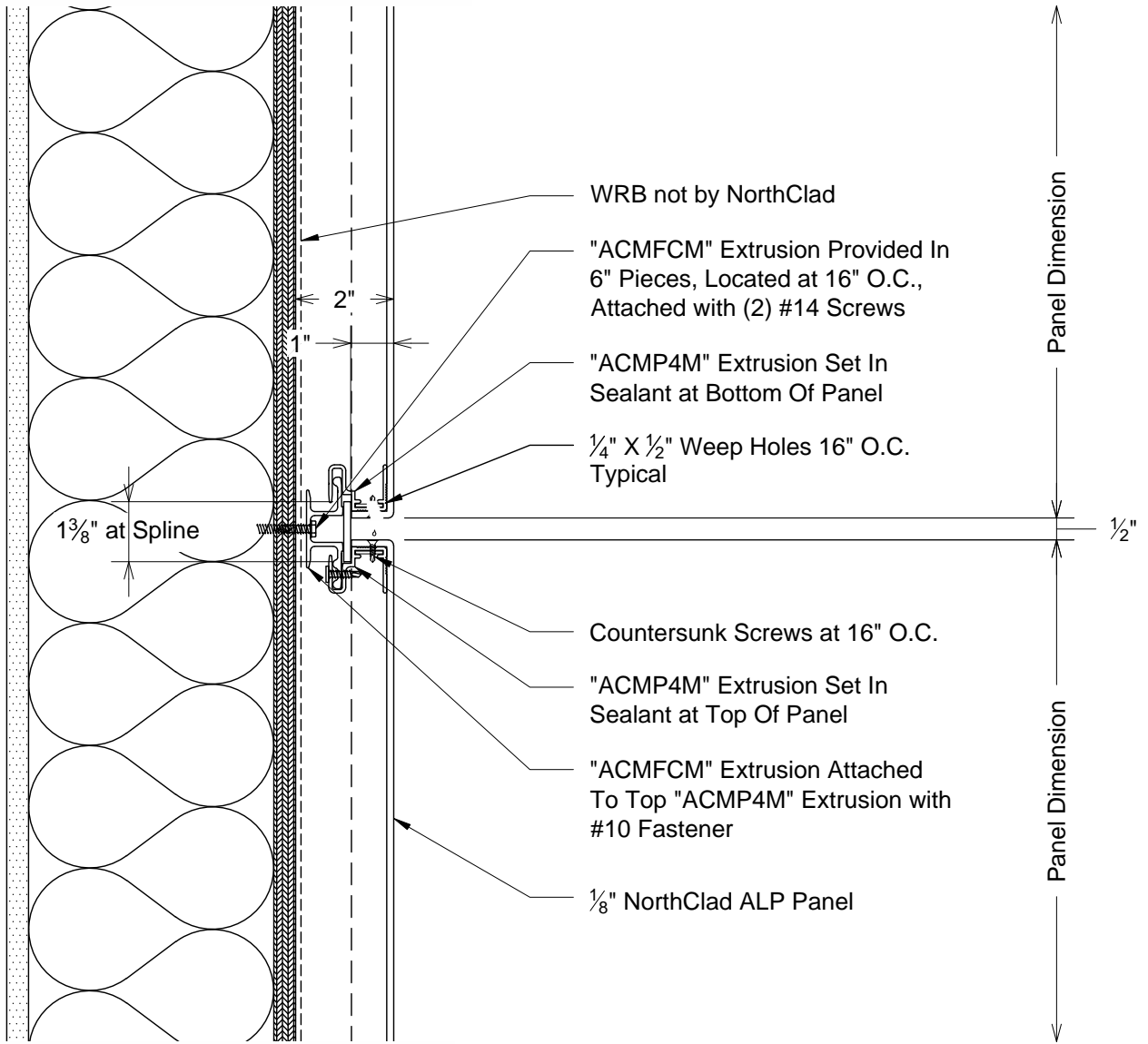

A
DET Section - Typical ALP Horizontal Panel Joint



11831 BEVERLY PARK RD. BUILDING C, EVERETT, WA 98204
 * PHONE: 425.740.3702 * FAX: 425.740.3701 *
 www.northclad.com

This document is property of NorthClad and should not be used, duplicated or modified without the express written consent. Copyright © 2010 NorthClad All Rights Reserved

NO.	DESCRIPTION	DATE	INIT.
1	Std Details	02.12.2014	M E
2			
3			
4			
5			
6			
7			
8			
9			
10			

Project
 ALP Dry Joint

Sheet Title	DET
Scale	3" = 1'-0"
Job Number	
Sheet	A
APPROVED	

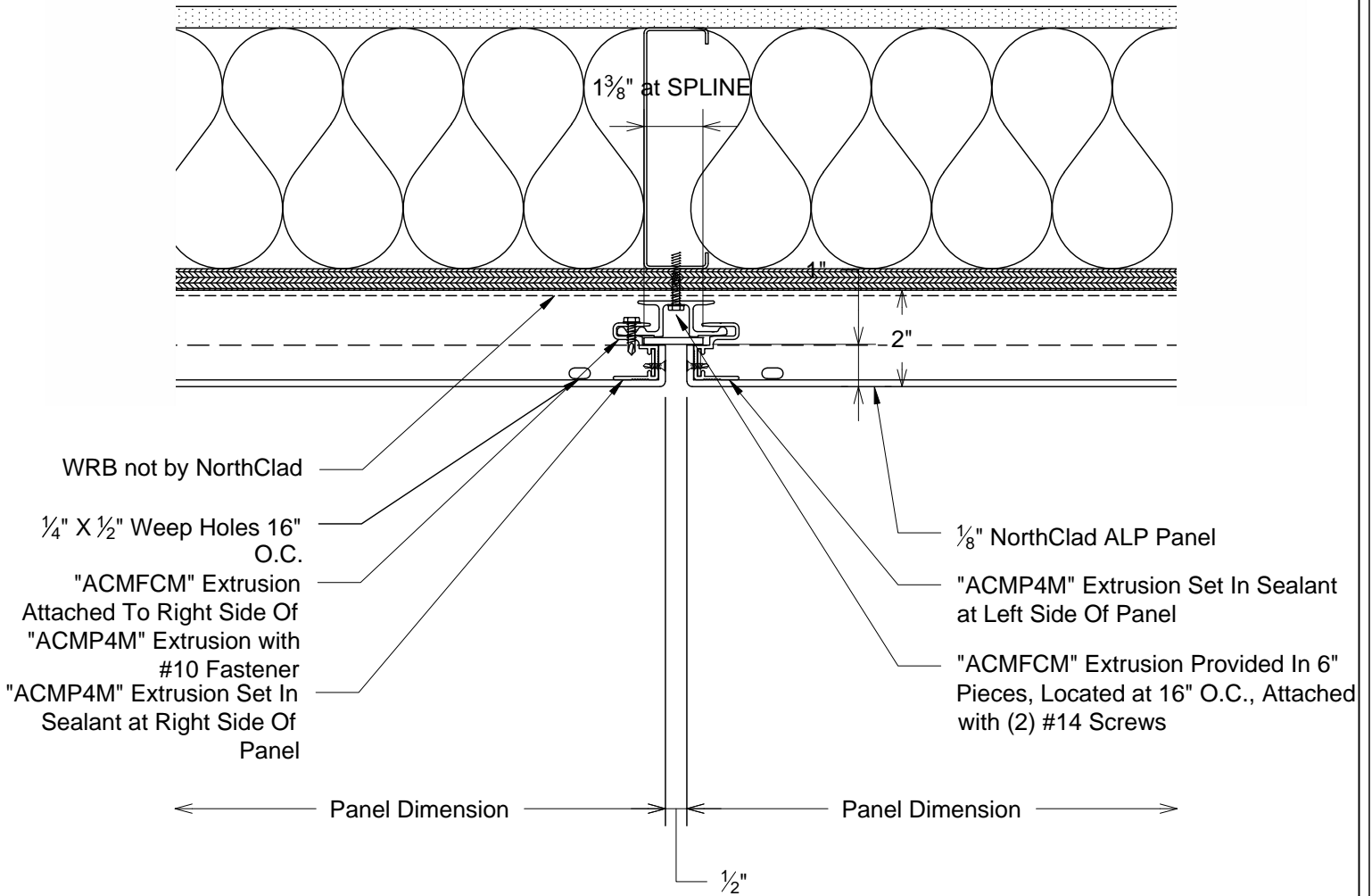

B
DET

Plan - Typical ALP Vertical Panel Joint



11831 BEVERLY PARK RD. BUILDING C, EVERETT, WA 98204
 * PHONE: 425.740.3702 * FAX: 425.740.3701 *
 www.northclad.com

This document is property of NorthClad and should not be used, duplicated or modified without the express written consent. Copyright © 2010 NorthClad All Rights Reserved

NO.	DESCRIPTION	DATE	INIT.
1	Std Details	02.12.2014	M E
2			
3			
4			
5			
6			
7			
8			
9			
10			

Project

ALP Dry Joint

Sheet Title	DET
Scale	3" = 1'-0"
Job Number	
Sheet	B
APPROVED	

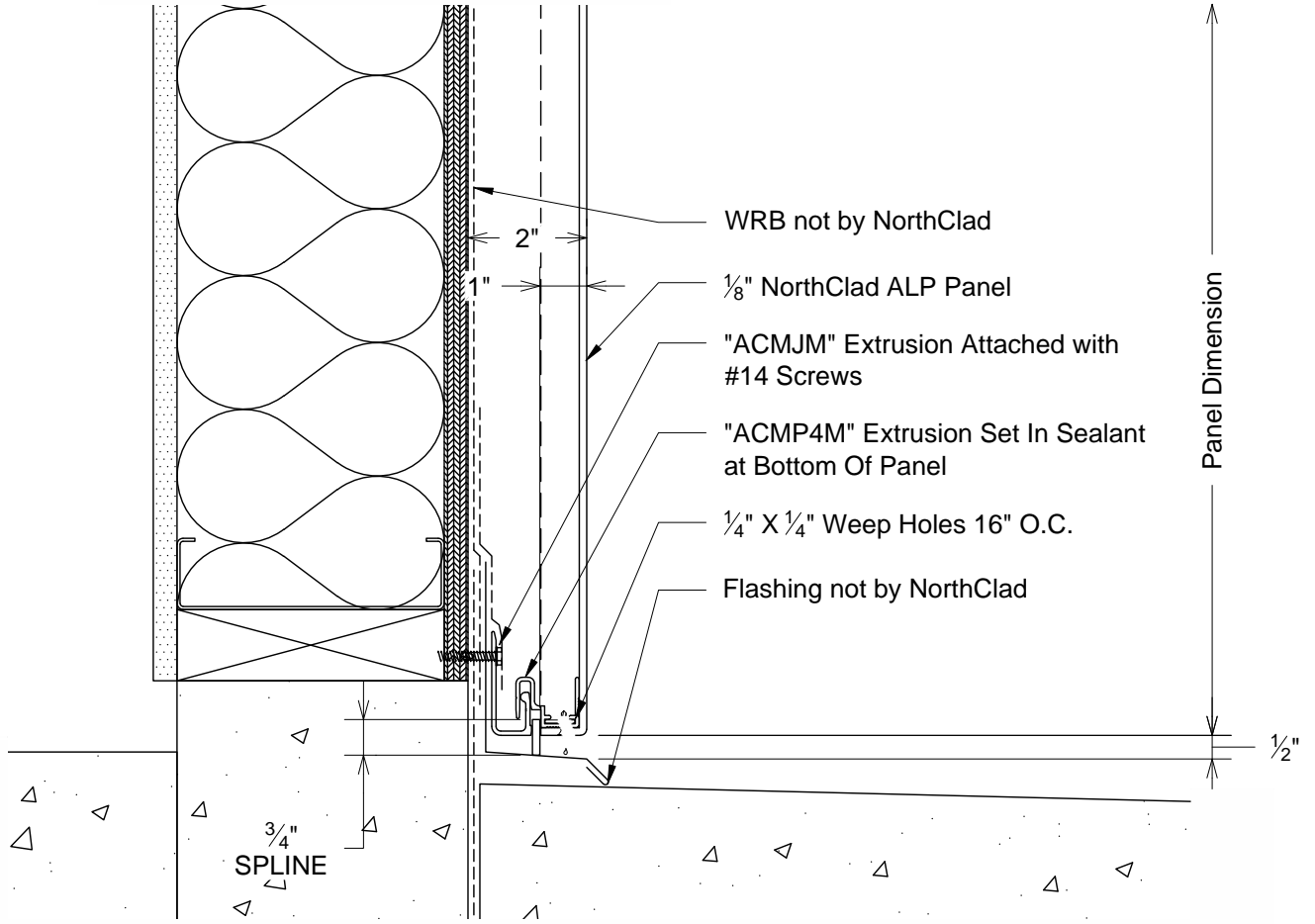

C
DET Section - ALP Base of Panel Wall



11831 BEVERLY PARK RD. BUILDING C, EVERETT, WA 98204
 * PHONE: 425.740.3702 * FAX: 425.740.3701 *
 www.northclad.com

This document is property of NorthClad and should not be used, duplicated or modified without the express written consent. Copyright © 2010 NorthClad All Rights Reserved

NO.	DESCRIPTION	DATE	INIT.
1	Std Details	02.12.2014	M E
2			
3			
4			
5			
6			
7			
8			
9			
10			

Project

ALP Dry Joint

Sheet Title	DET
Scale	3" = 1'-0"
Job Number	
Sheet	C
APPROVED	

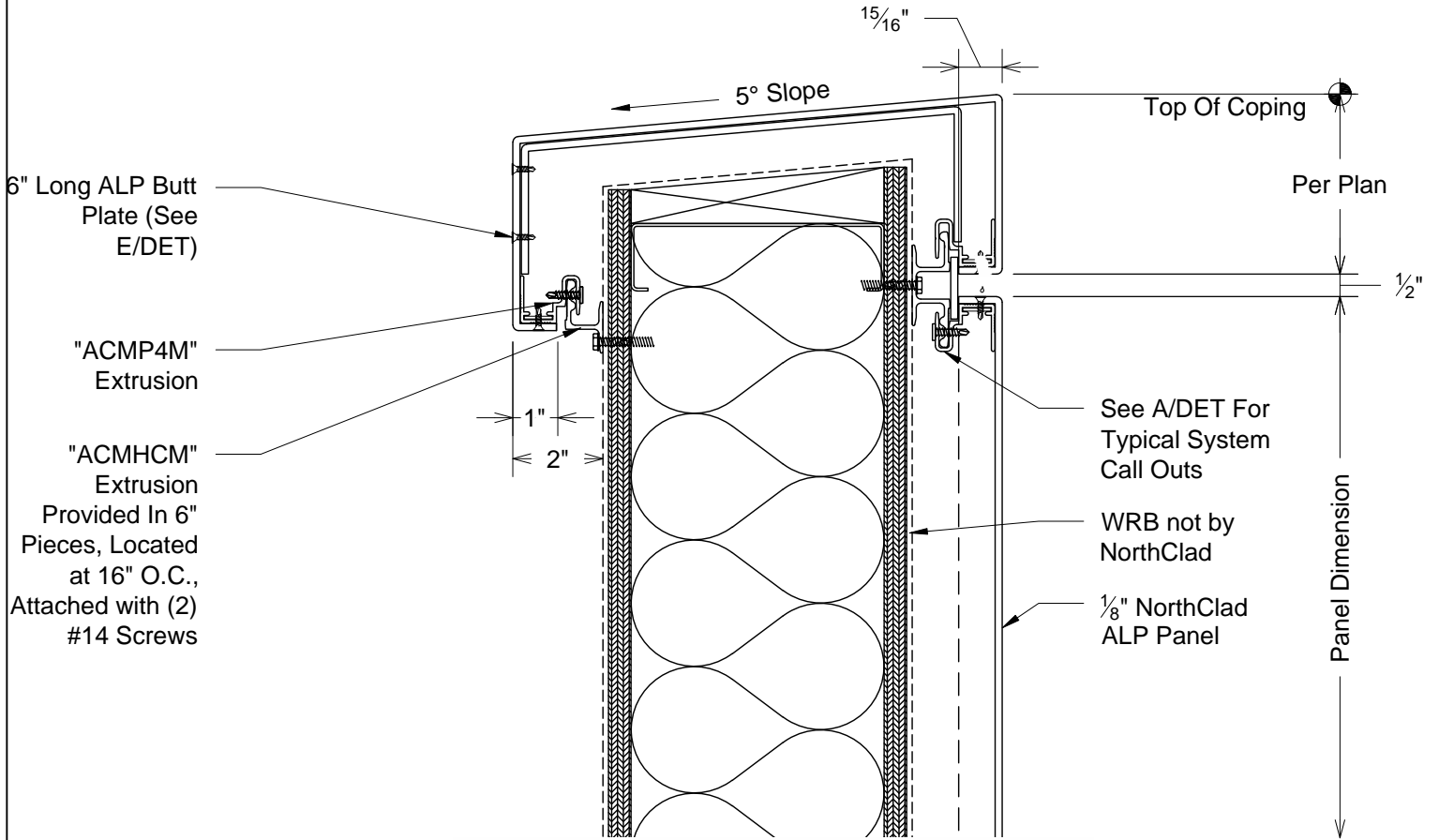

D Section - ALP Panel Copping
DET



11831 BEVERLY PARK RD. BUILDING C, EVERETT, WA 98204
* PHONE: 425.740.3702 * FAX: 425.740.3701 *
www.northclad.com

This document is property of NorthClad and should not be used, duplicated or modified without the express written consent. Copyright © 2010 NorthClad All Rights Reserved

NO.	DESCRIPTION	DATE	INIT.
1	Std Details	02.12.2014	M E
2			
3			
4			
5			
6			
7			
8			
9			
10			

Project

ALP Dry Joint

Sheet Title
DET

Scale
3" = 1'-0"

Job Number

Sheet
D

APPROVED

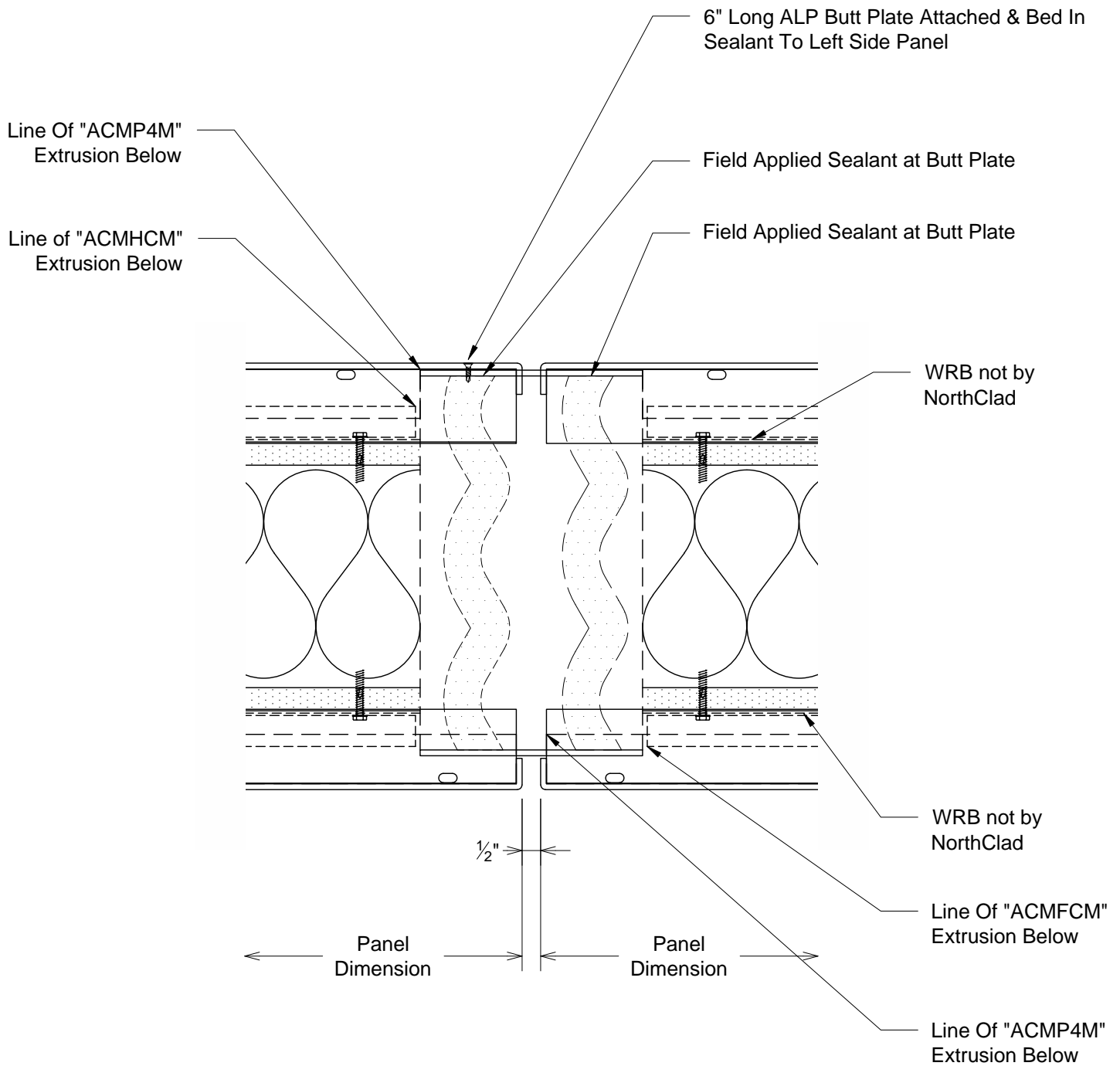

E
DET
Plan - ALP Panel Coping Splice



11831 BEVERLY PARK RD. BUILDING C, EVERETT, WA 98204
* PHONE: 425.740.3702 * FAX: 425.740.3701 *
www.northclad.com

This document is property of NorthClad and should not be used, duplicated or modified without the express written consent. Copyright © 2010 NorthClad All Rights Reserved

NO.	DESCRIPTION	DATE	INIT.
1	Std Details	02.12.2014	M E
2			
3			
4			
5			
6			
7			
8			
9			
10			

Project

ALP Dry Joint

Sheet Title
DET

Scale
3" = 1'-0"

Job Number

Sheet
E

APPROVED

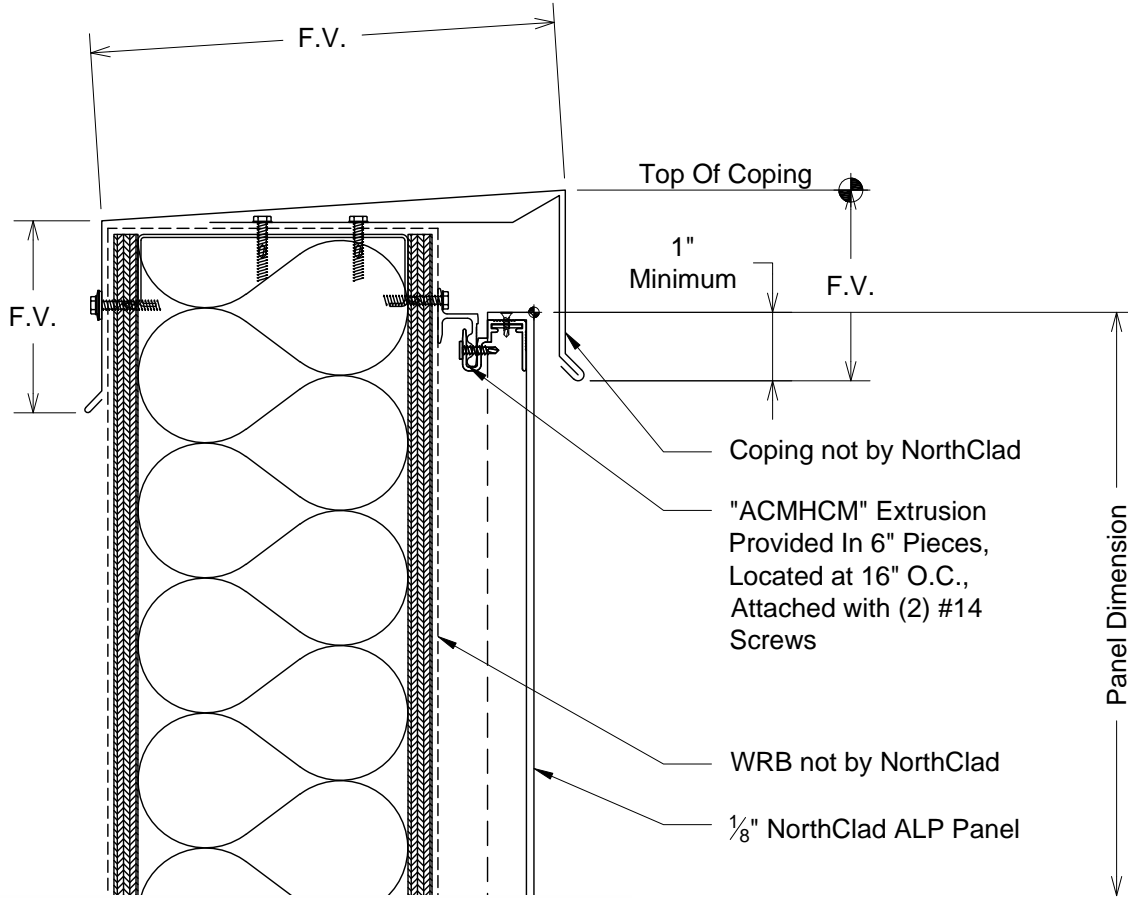

F Section - ALP Panel at Light Gauge Formed Coping
DET



11831 BEVERLY PARK RD. BUILDING C, EVERETT, WA 98204
* PHONE: 425.740.3702 * FAX: 425.740.3701 *
www.northclad.com

This document is property of NorthClad and should not be used, duplicated or modified without the express written consent. Copyright © 2010 NorthClad All Rights Reserved

NO.	DESCRIPTION	DATE	INIT.
1	Std Details	02.12.2014	M E
2			
3			
4			
5			
6			
7			
8			
9			
10			

Project
ALP Dry Joint

Sheet Title	DET
Scale	3" = 1'-0"
Job Number	
Sheet	F
APPROVED	

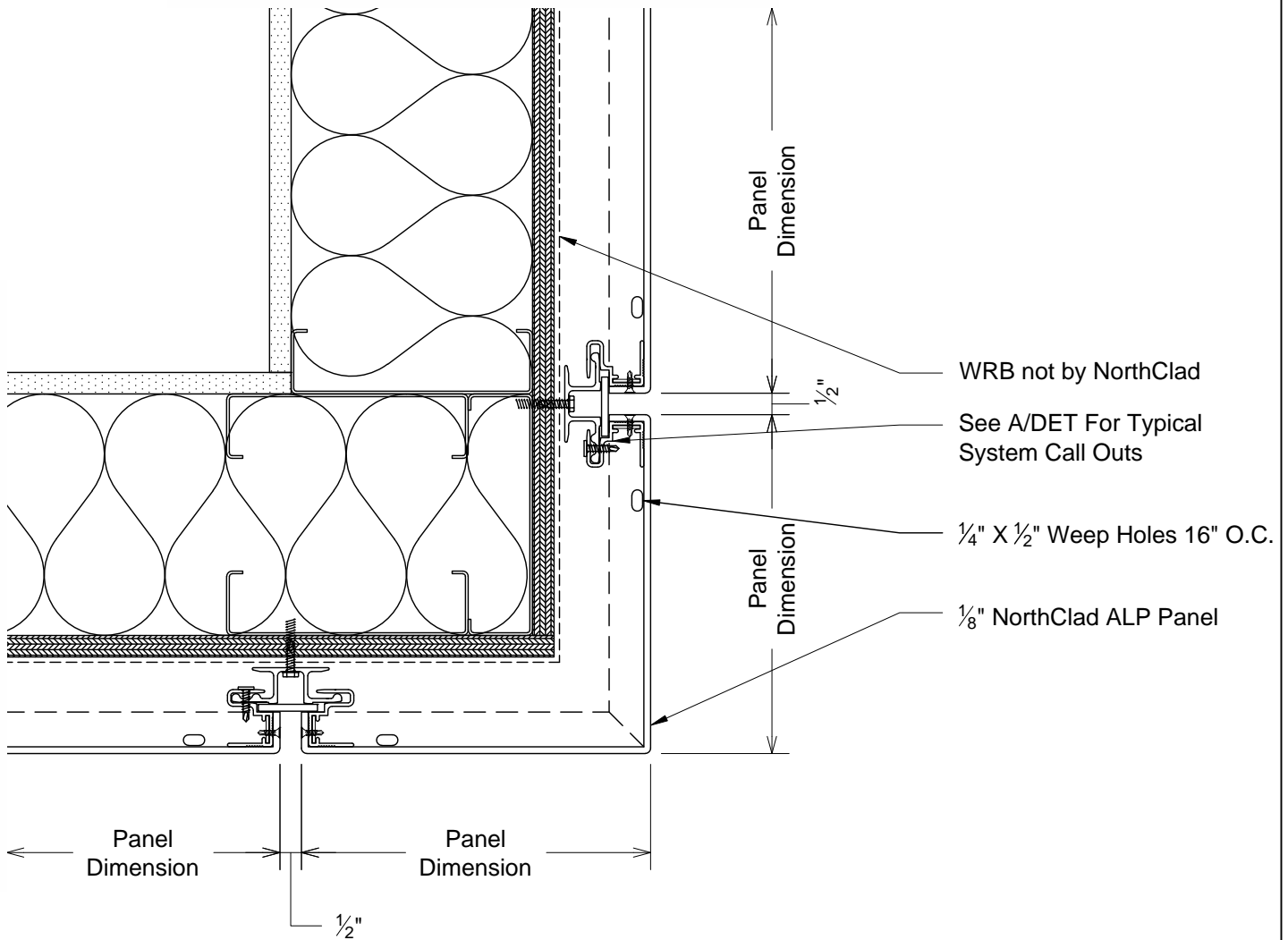

G
DET
Plan - ALP Outside Corner



11831 BEVERLY PARK RD. BUILDING C, EVERETT, WA 98204
 * PHONE: 425.740.3702 * FAX: 425.740.3701 *
 www.northclad.com

This document is property of NorthClad and should not be used, duplicated or modified without the express written consent. Copyright © 2010 NorthClad All Rights Reserved

NO.	DESCRIPTION	DATE	INIT.
1	Std Details	02.12.2014	M E
2			
3			
4			
5			
6			
7			
8			
9			
10			

Project

ALP Dry Joint

Sheet Title	DET
Scale	3" = 1'-0"
Job Number	
Sheet	G
APPROVED	

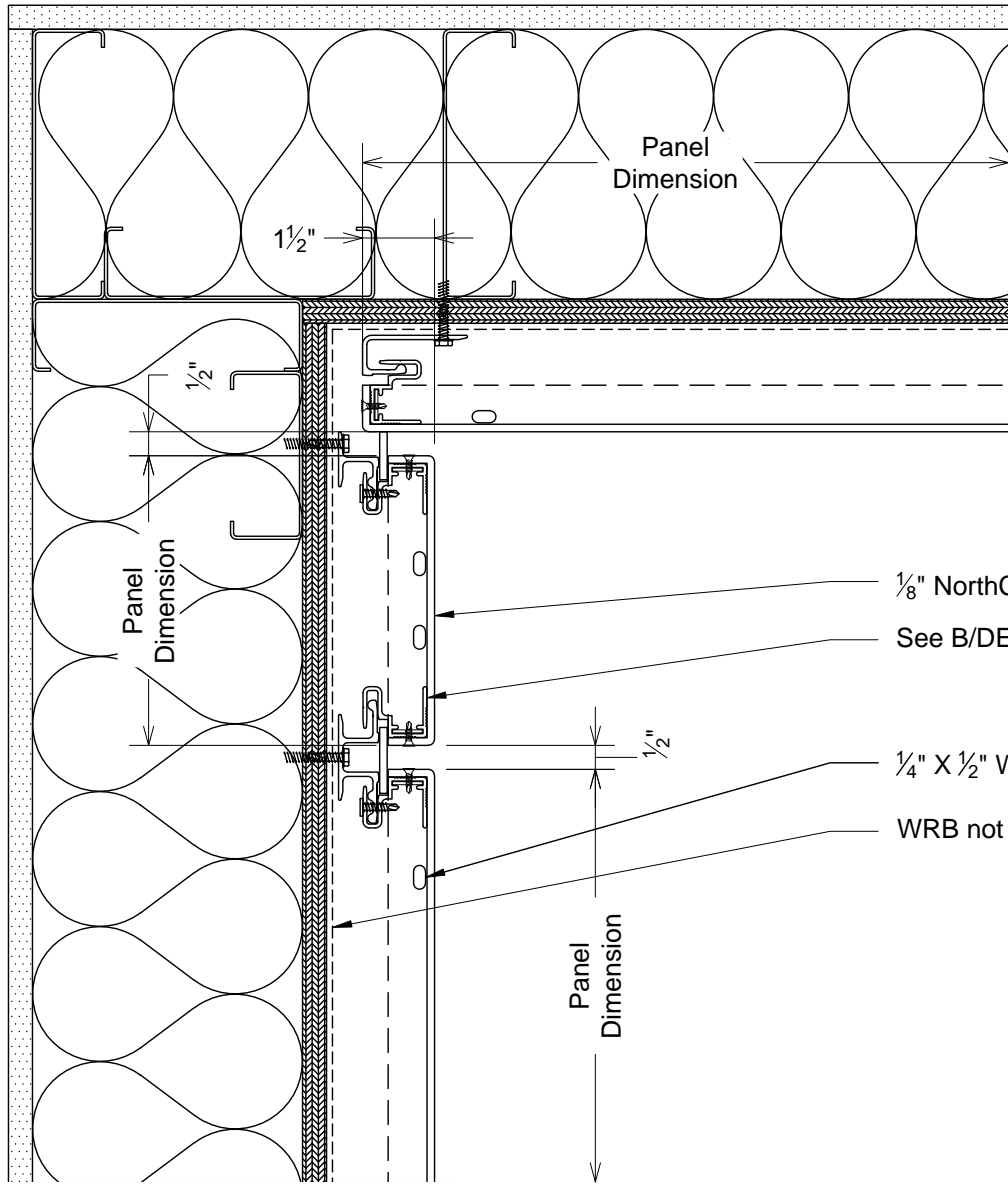

- 1/8" NorthClad ALP Panel
- See B/DET For Typical System Call Outs
- 1/4" X 1/2" Weep Holes 16" O.C.
- WRB not by NorthClad

H
DET
Plan - ALP Inside Corner



11831 BEVERLY PARK RD. BUILDING C, EVERETT, WA 98204
 * PHONE: 425.740.3702 * FAX: 425.740.3701 *
 www.northclad.com

This document is property of NorthClad and should not be used, duplicated or modified without the express written consent. Copyright © 2010 NorthClad All Rights Reserved

NO.	DESCRIPTION	DATE	INIT.
1	Std Details	02.12.2014	M E
2			
3			
4			
5			
6			
7			
8			
9			
10			

Project
 ALP Dry Joint

Sheet Title	DET
Scale	3" = 1'-0"
Job Number	
Sheet	H
APPROVED	

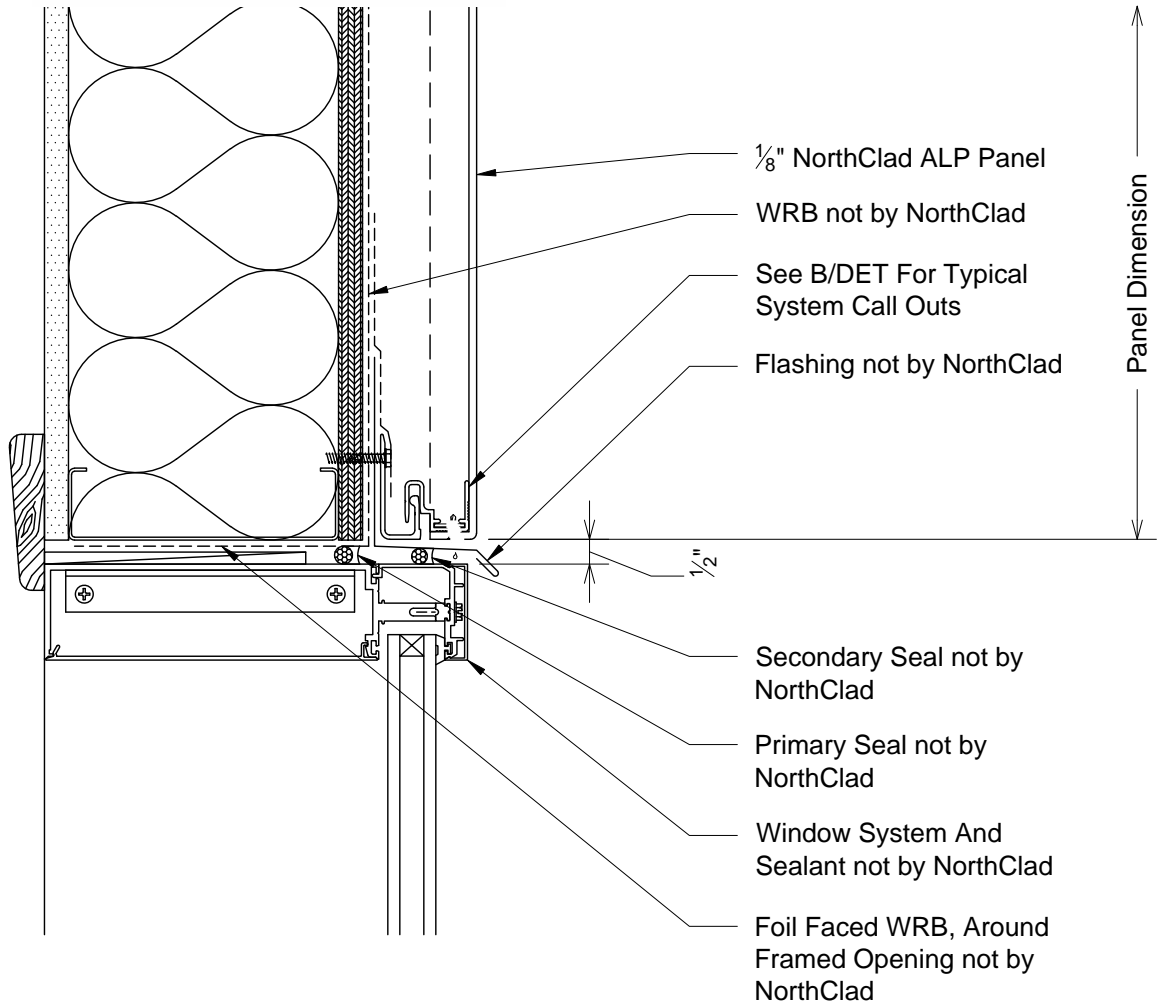

J
DET

Section - ALP Panel at Window/CW Head



11831 BEVERLY PARK RD. BUILDING C, EVERETT, WA 98204
 * PHONE: 425.740.3702 * FAX: 425.740.3701 *
 www.northclad.com

This document is property of NorthClad and should not be used, duplicated or modified without the express written consent. Copyright © 2010 NorthClad All Rights Reserved

NO.	DESCRIPTION	DATE	INIT.
1	Std Details	02.12.2014	M E
2			
3			
4			
5			
6			
7			
8			
9			
10			

Project

ALP Dry Joint

Sheet Title	DET
Scale	3" = 1'-0"
Job Number	
Sheet	J
APPROVED	

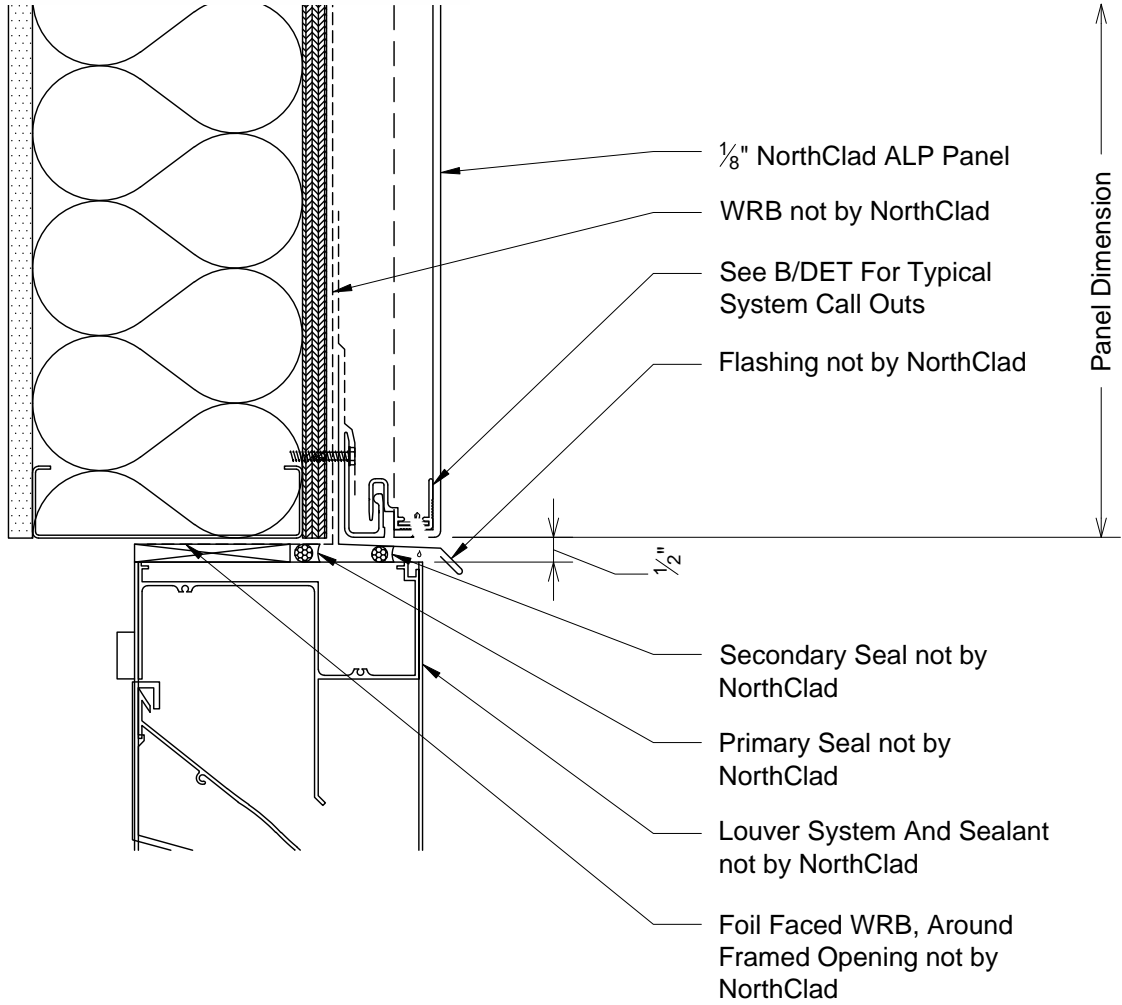

K
DET Section - ALP Panel at Louver Head



11831 BEVERLY PARK RD. BUILDING C, EVERETT, WA 98204
 * PHONE: 425.740.3702 * FAX: 425.740.3701 *
 www.northclad.com

This document is property of NorthClad and should not be used, duplicated or modified without the express written consent. Copyright © 2010 NorthClad All Rights Reserved

NO.	DESCRIPTION	DATE	INIT.
1	Std Details	02.12.2014	M E
2			
3			
4			
5			
6			
7			
8			
9			
10			

Project

ALP Dry Joint

Sheet Title	DET
Scale	3" = 1'-0"
Job Number	
Sheet	K
APPROVED	

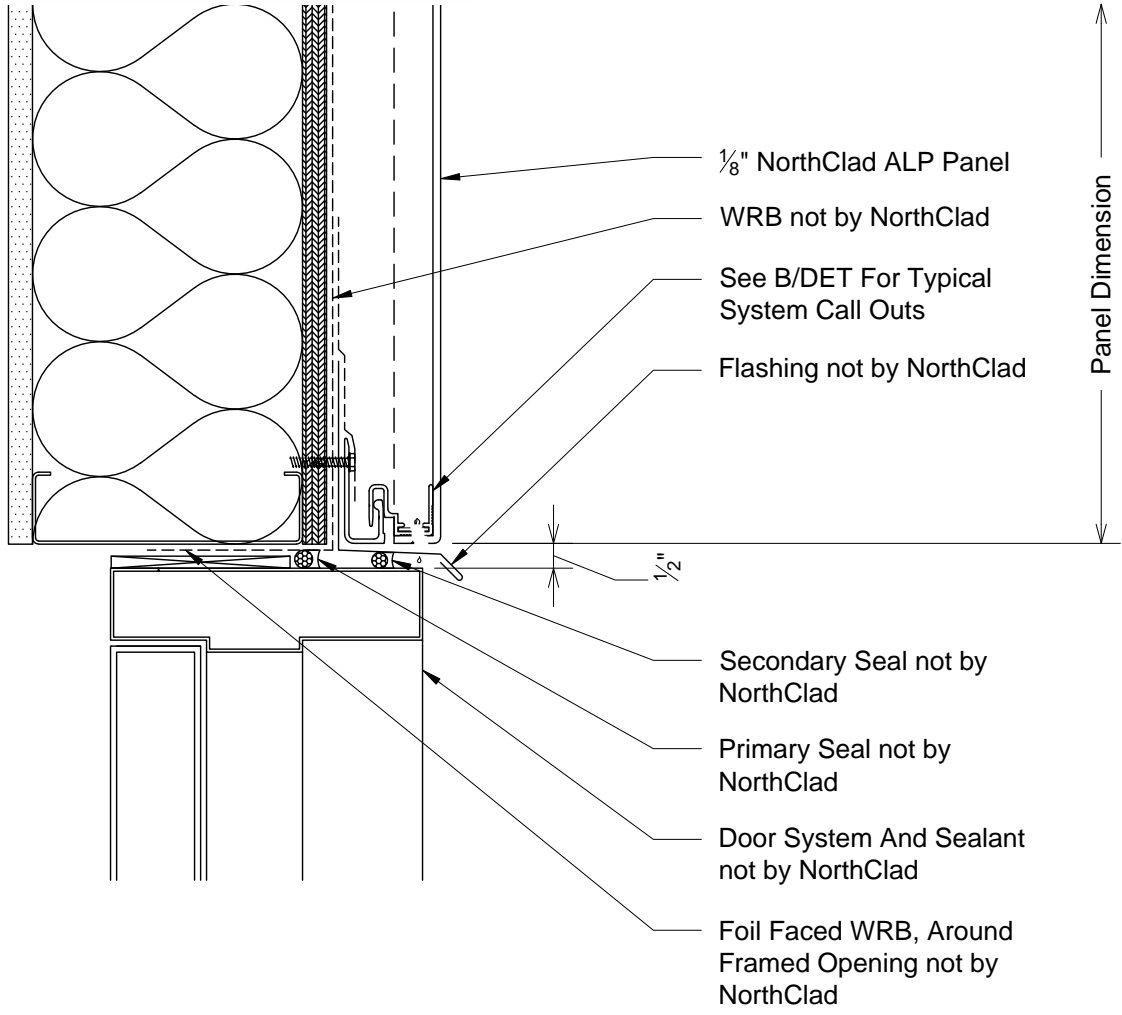

M
DET Section - ALP Panel at Hollow Metal Door Head



11831 BEVERLY PARK RD. BUILDING C, EVERETT, WA 98204
 * PHONE: 425.740.3702 * FAX: 425.740.3701 *
 www.northclad.com

This document is property of NorthClad and should not be used, duplicated or modified without the express written consent. Copyright © 2010 NorthClad All Rights Reserved

NO.	DESCRIPTION	DATE	INIT.
1	Std Details	02.12.2014	M E
2			
3			
4			
5			
6			
7			
8			
9			
10			

Project

ALP Dry Joint

Sheet Title	DET
Scale	3" = 1'-0"
Job Number	
Sheet	M
APPROVED	

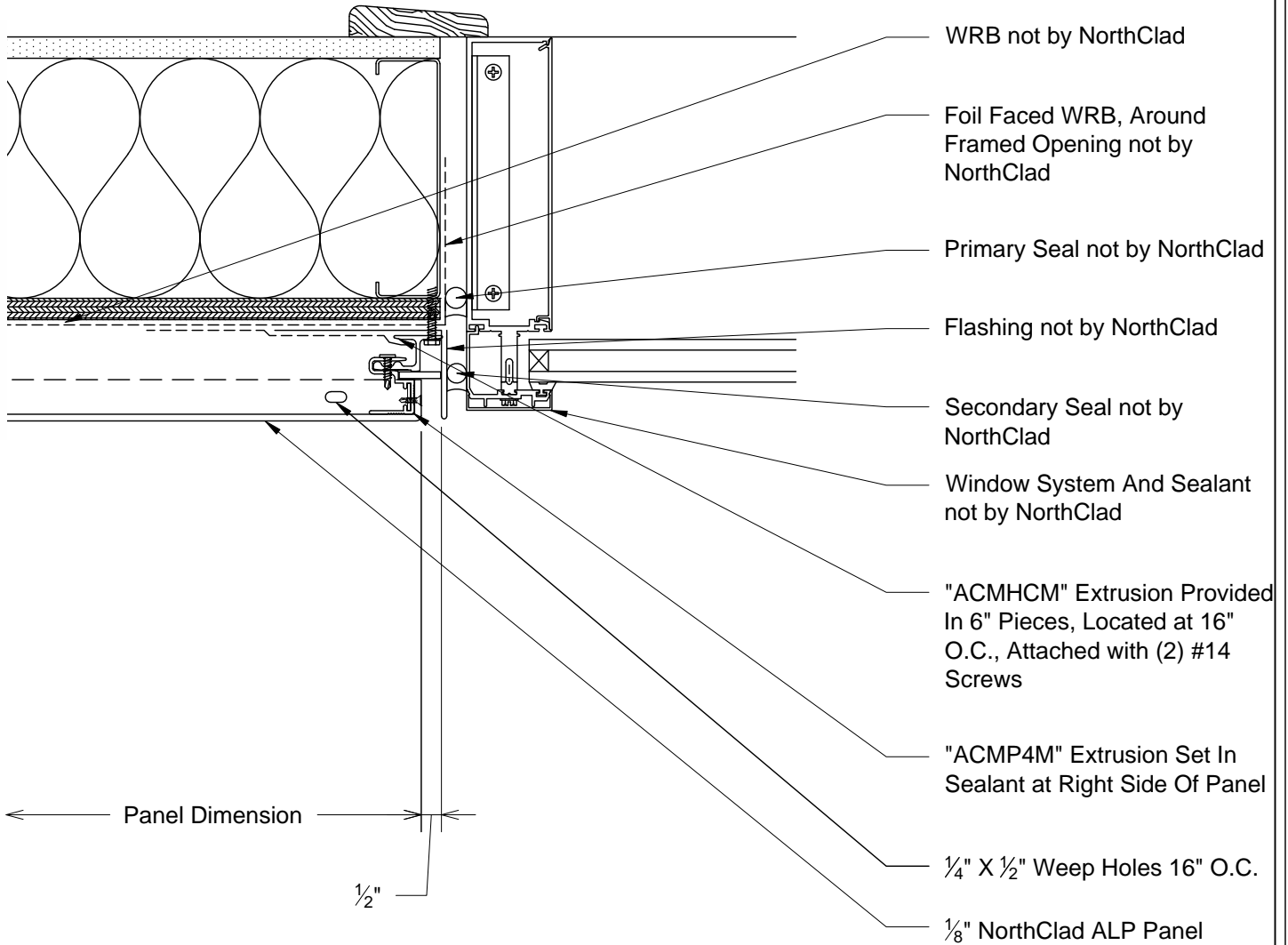

N
DET

 Plan - ALP Panel at Left Side Window/CW Jamb



11831 BEVERLY PARK RD. BUILDING C, EVERETT, WA 98204
 * PHONE: 425.740.3702 * FAX: 425.740.3701 *
 www.northclad.com

This document is property of NorthClad and should not be used, duplicated or modified without the express written consent. Copyright © 2010 NorthClad All Rights Reserved

NO.	DESCRIPTION	DATE	INIT.
1	Std Details	02.12.2014	M E
2			
3			
4			
5			
6			
7			
8			
9			
10			

Project

ALP Dry Joint

Sheet Title	DET
Scale	3" = 1'-0"
Job Number	
Sheet	N
APPROVED	

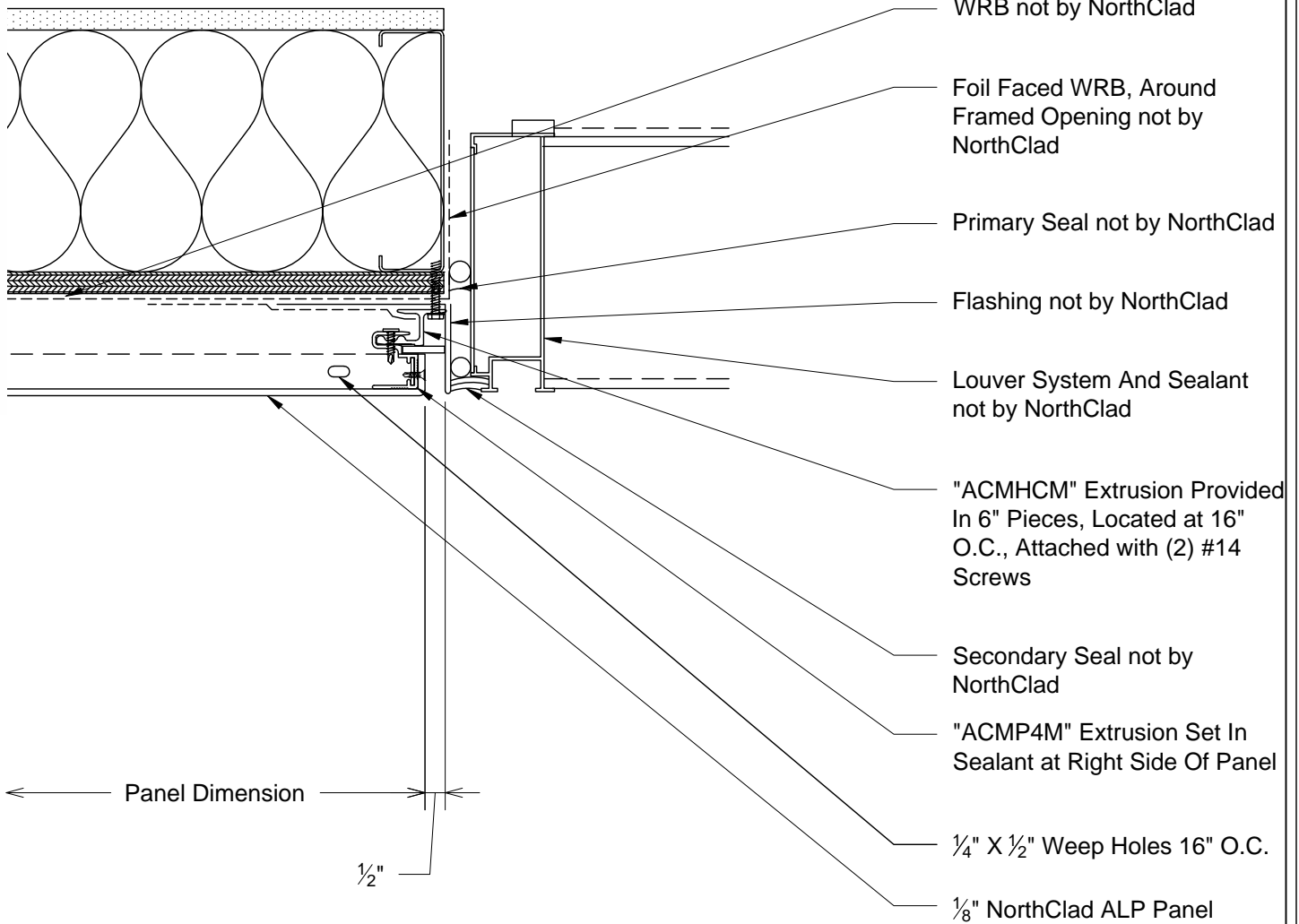

P
DET

 Plan - ALP Panel at Left Side Louver Jamb



11831 BEVERLY PARK RD. BUILDING C, EVERETT, WA 98204
 * PHONE: 425.740.3702 * FAX: 425.740.3701 *
 www.northclad.com

This document is property of NorthClad and should not be used, duplicated or modified without the express written consent. Copyright © 2010 NorthClad All Rights Reserved

NO.	DESCRIPTION	DATE	INIT.
1	Std Details	02.12.2014	M E
2			
3			
4			
5			
6			
7			
8			
9			
10			

Project

ALP Dry Joint

Sheet Title	DET
Scale	3" = 1'-0"
Job Number	
Sheet	P
APPROVED	

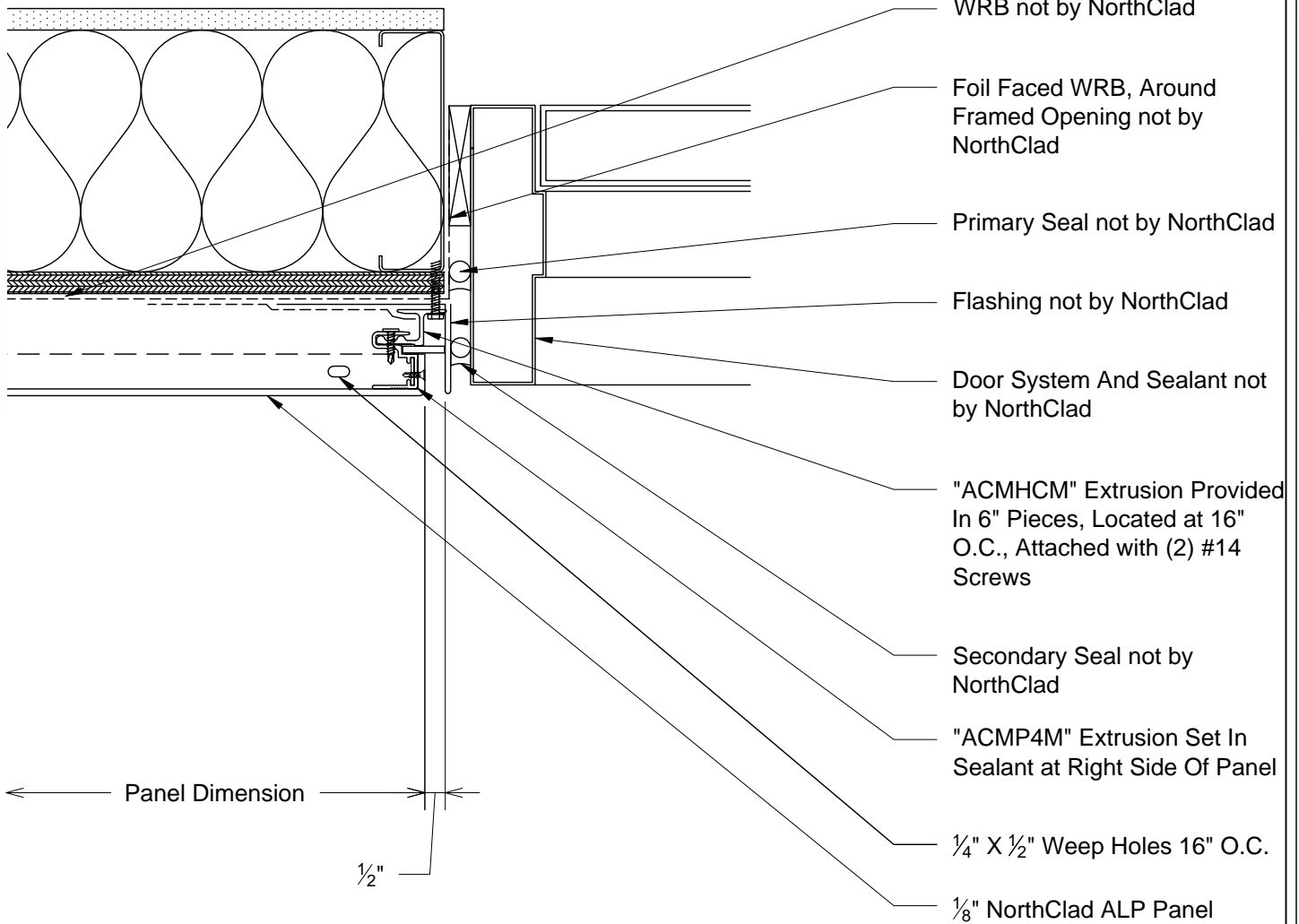

Q Plan - ALP Panel at Left Side Hollow Metal Door Jamb
DET



11831 BEVERLY PARK RD. BUILDING C, EVERETT, WA 98204
* PHONE: 425.740.3702 * FAX: 425.740.3701 *
www.northclad.com

This document is property of NorthClad and should not be used, duplicated or modified without the express written consent. Copyright © 2010 NorthClad All Rights Reserved

NO.	DESCRIPTION	DATE	INIT.
1	Std Details	02.12.2014	M E
2			
3			
4			
5			
6			
7			
8			
9			
10			

Project

ALP Dry Joint

Sheet Title	DET
Scale	3" = 1'-0"
Job Number	
Sheet	Q
APPROVED	

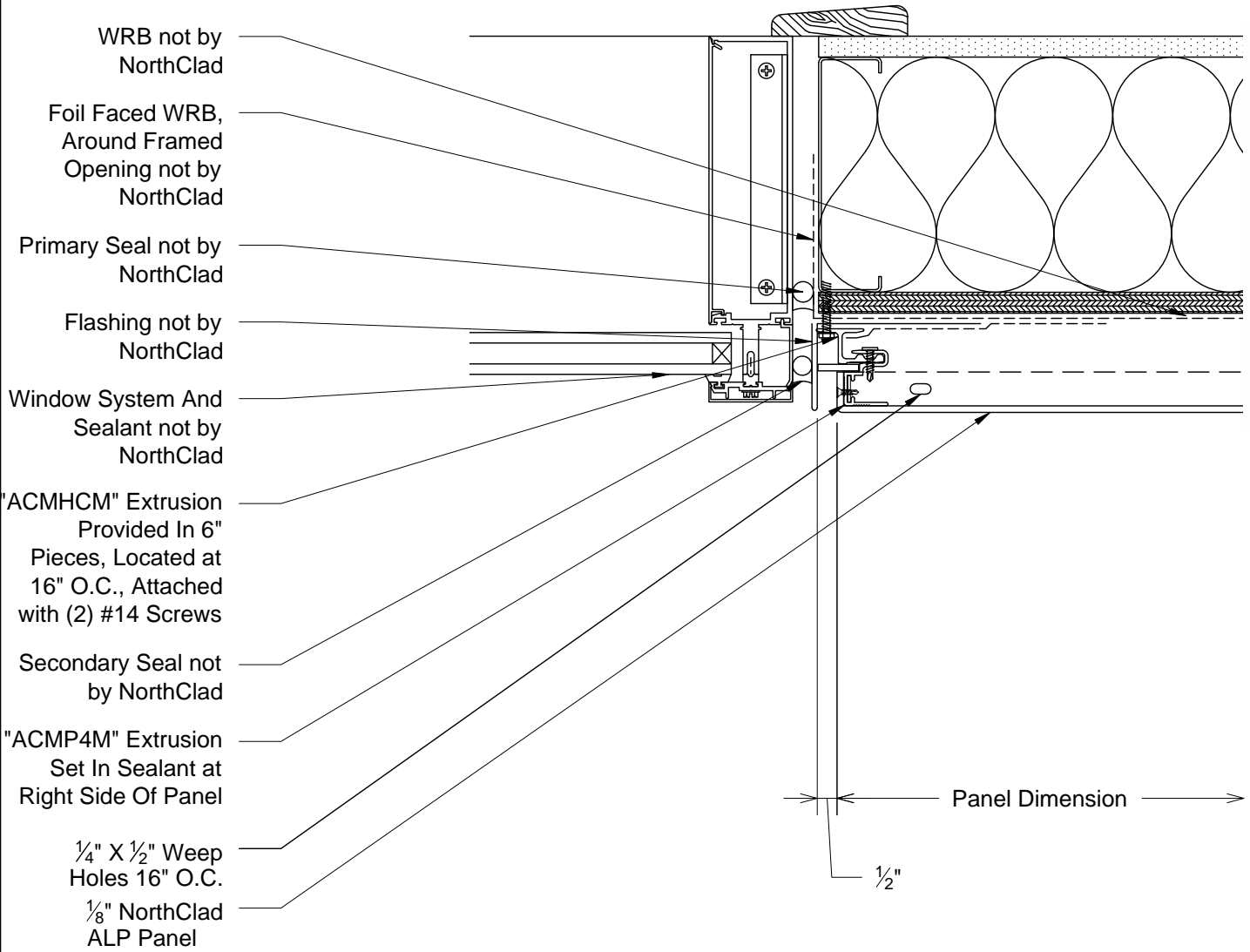

R
DET
Plan - ALP Panel at Right Side Window/CW Jamb



11831 BEVERLY PARK RD. BUILDING C, EVERETT, WA 98204
 * PHONE: 425.740.3702 * FAX: 425.740.3701 *
 www.northclad.com

This document is property of NorthClad and should not be used, duplicated or modified without the express written consent. Copyright © 2010 NorthClad All Rights Reserved

NO.	DESCRIPTION	DATE	INIT.
1	Std Details	02.12.2014	M E
2			
3			
4			
5			
6			
7			
8			
9			
10			

Project

ALP Dry Joint

Sheet Title	DET
Scale	3" = 1'-0"
Job Number	
Sheet	R
APPROVED	

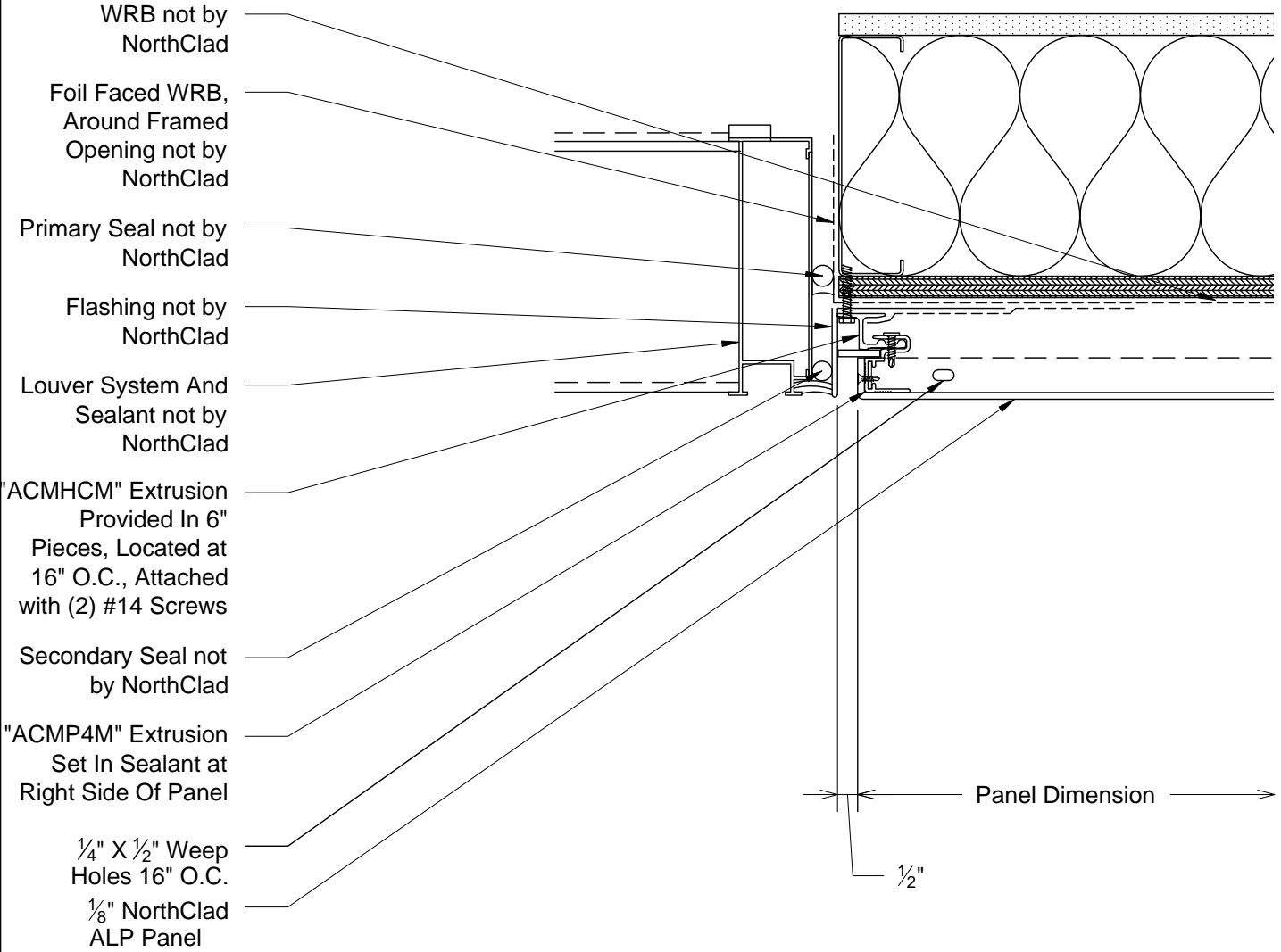

S
DET

Plan - ALP Panel at Right Side Louver Jamb



11831 BEVERLY PARK RD. BUILDING C, EVERETT, WA 98204
 * PHONE: 425.740.3702 * FAX: 425.740.3701 *
 www.northclad.com

This document is property of NorthClad and should not be used, duplicated or modified without the express written consent. Copyright © 2010 NorthClad All Rights Reserved

NO.	DESCRIPTION	DATE	INIT.
1	Std Details	02.12.2014	M E
2			
3			
4			
5			
6			
7			
8			
9			
10			

Project

ALP Dry Joint

Sheet Title	DET
Scale	3" = 1'-0"
Job Number	
Sheet	S
APPROVED	

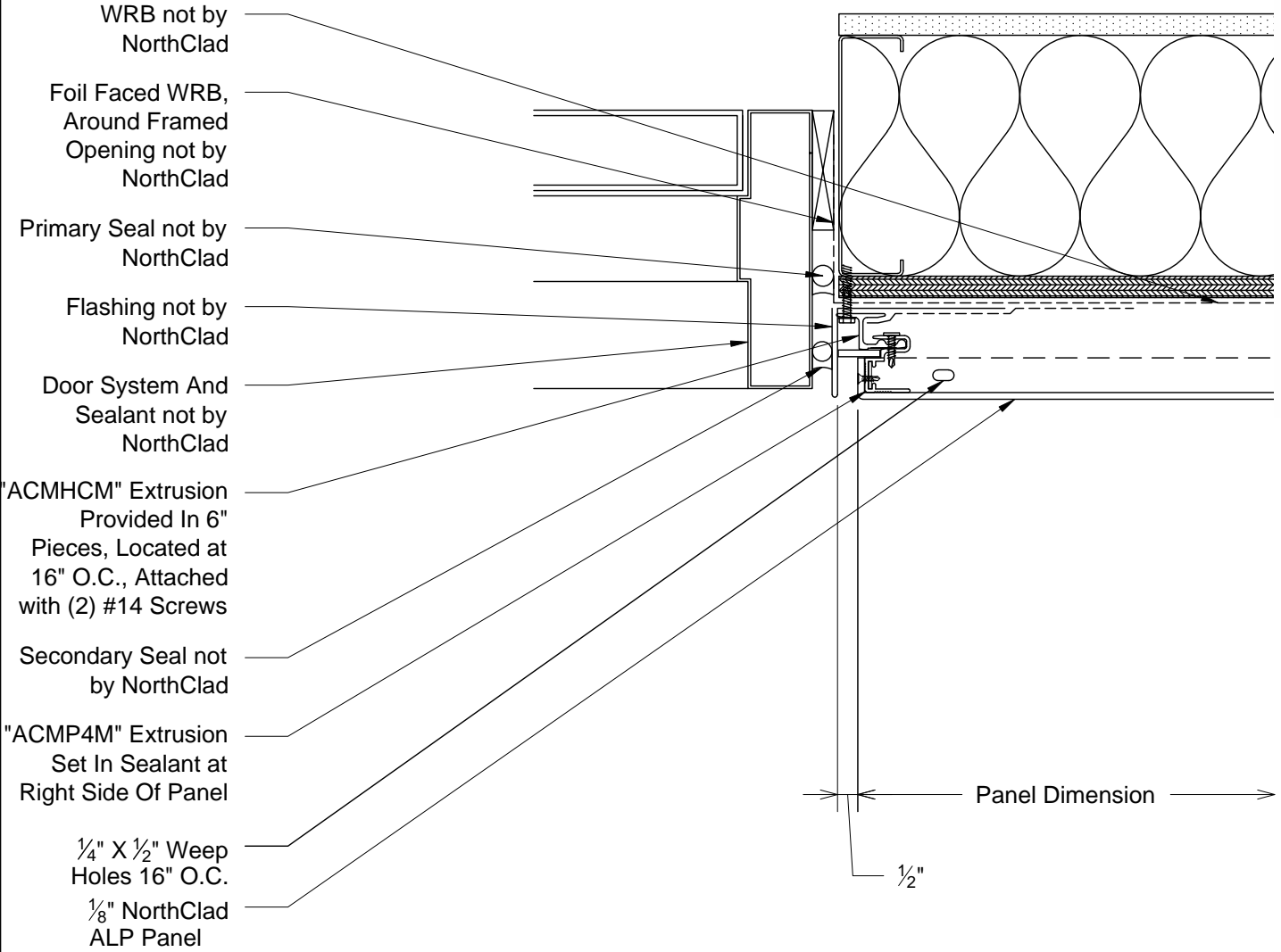

T
DET

Plan - ALP Panel at Right Side Hollow Metal Door Jamb



11831 BEVERLY PARK RD. BUILDING C, EVERETT, WA 98204
 * PHONE: 425.740.3702 * FAX: 425.740.3701 *
 www.northclad.com

This document is property of NorthClad and should not be used, duplicated or modified without the express written consent. Copyright © 2010 NorthClad All Rights Reserved

NO.	DESCRIPTION	DATE	INIT.
1	Std Details	02.12.2014	M E
2			
3			
4			
5			
6			
7			
8			
9			
10			

Project

ALP Dry Joint

Sheet Title **DET**

Scale **3" = 1'-0"**

Job Number

Sheet **T**

APPROVED

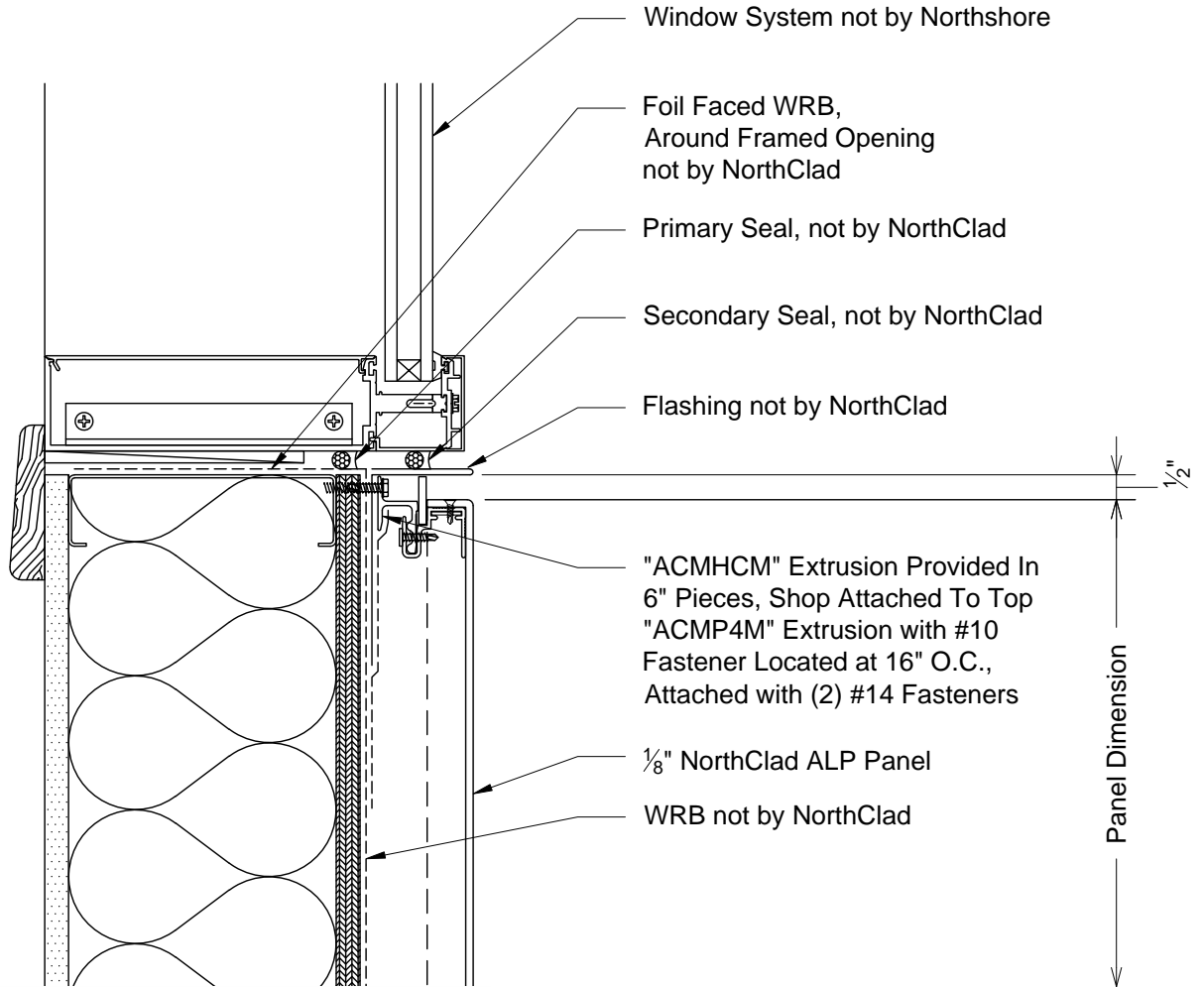

U Section - ALP Panel at Window/CW Sill
DET



11831 BEVERLY PARK RD. BUILDING C, EVERETT, WA 98204
* PHONE: 425.740.3702 * FAX: 425.740.3701 *
www.northclad.com

This document is property of NorthClad and should not be used, duplicated or modified without the express written consent. Copyright © 2010 NorthClad All Rights Reserved

NO.	DESCRIPTION	DATE	INIT.
1	Std Details	02.12.2014	M E
2			
3			
4			
5			
6			
7			
8			
9			
10			

Project
ALP Dry Joint

Sheet Title	DET
Scale	3" = 1'-0"
Job Number	
Sheet	U
APPROVED	

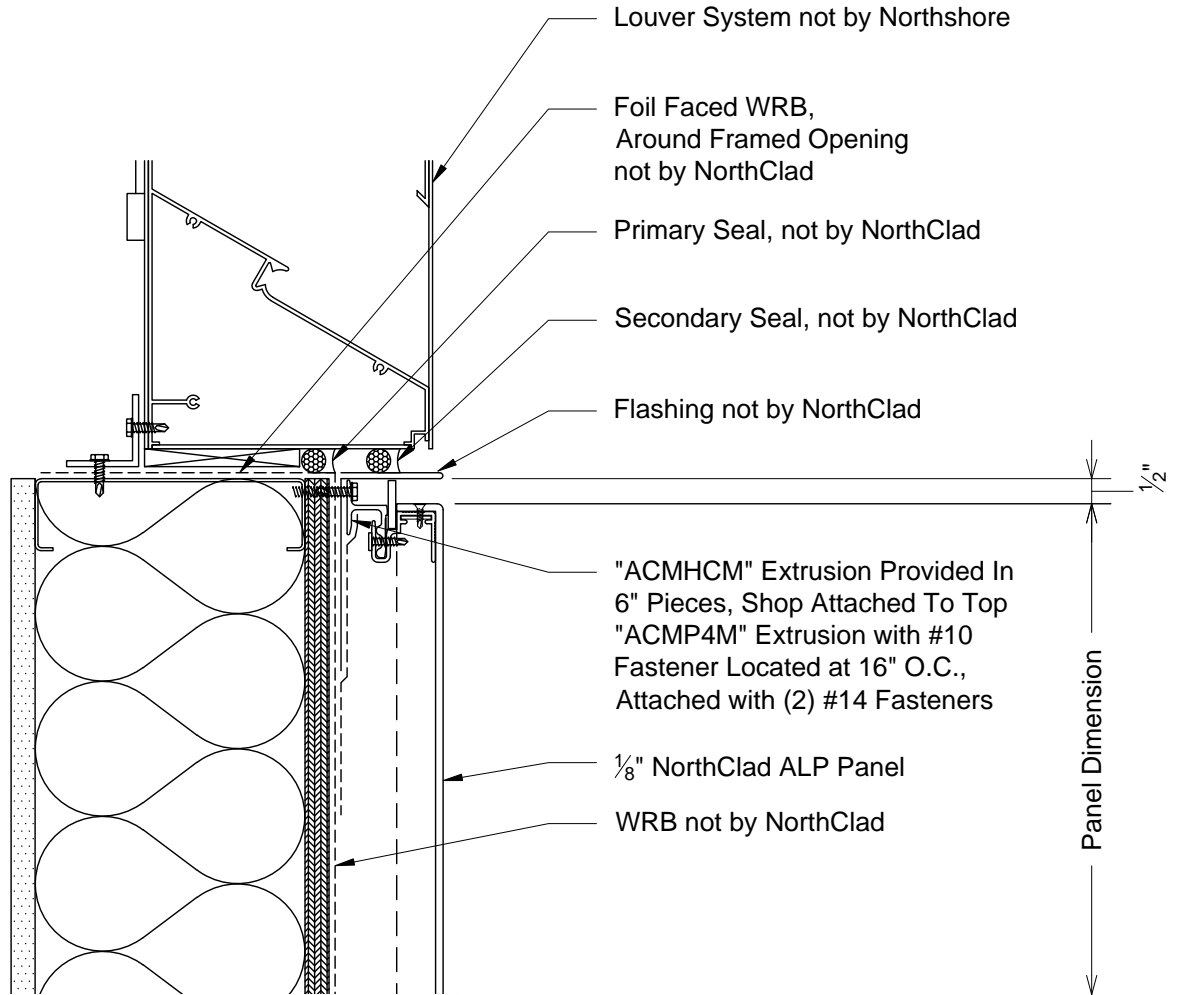

V
DET Section - ALP Panel at Louver Sill



11831 BEVERLY PARK RD. BUILDING C, EVERETT, WA 98204
 * PHONE: 425.740.3702 * FAX: 425.740.3701 *
 www.northclad.com

This document is property of NorthClad and should not be used, duplicated or modified without the express written consent. Copyright © 2010 NorthClad All Rights Reserved

NO.	DESCRIPTION	DATE	INIT.
1	Std Details	02.12.2014	M E
2			
3			
4			
5			
6			
7			
8			
9			
10			

Project

ALP Dry Joint

Sheet Title
DET

Scale
3" = 1'-0"

Job Number

Sheet
V

APPROVED